

WIWA High-Performance Dual Component Airless Paint Spraying Equipment

DUOMIX



DUOMIX -
In world-wide applications, this WIWA Dual Component Series has proven its effectiveness coating large surface areas.

Mixing ratios
from 1:1 to 8:1

Outputs per cycle
up to 700 ccm

Pressure ratios
up to 85:1

Due to its unique design,
the WIWA DUOMIX can also
be adapted for three component spraying.



Perfect Solutions for all
Fields of Application

- Economical
- Wide range of available performance ratings
- Individual solutions through modular variety
- Environmentally friendly reduction in solvent use
- Explosion-proof, pneumatic system

Flush Pump



Pressure and Metering Monitor



Mixing Block

WIWA DUOMIX 300 and 333

The rational solution for coating large surface areas is the WIWA-DUOMIX Dual Component System

ECONOMICAL AND ECOLOGICAL

The demands on the protective attributes of coatings are growing ever higher. Surfaces with high resistance to climatic, chemical and mechanical influences are required.

Production and space requirements call for very short curing times. Furthermore, to meet ecological standards, coatings must be applied with a minimum amount of solvent.

The solution to these various expectations is provided by plural component coating materials and the corresponding equipment technology. In direct cooperation with leading paint manufacturers, WIWA has developed and optimized effective plural component spraying equipment.

Reduction in Costs for Coating Materials

Coating materials can be drawn from large, recyclable, space-saving containers (drums, tanks, etc.).

No loss of material due to residue left in emptied paint cans.

The expensive disposal of paint cans with residue (hazardous materials) is eliminated.

Material is also saved, especially when using long hoses, through the effective high pressure flush pumps WIWA offers. The high pressure ratio and output of these pumps enable mixed material still located in the spraying hoses to first be applied before flushing the system at the end of work.

No material loss due to excess pre-mixed paint, as the WIWA DUOMIX only draws and mixes as much material as is required.

No solvents are necessary for processing high-viscosity materials.

Additional solvent savings are realized when cleaning the system, since only those parts which come in contact with mixed material must be flushed.

Reduction in Labor Costs

No extra personnel required for manually mixing the materials to be sprayed.

Due to the high pressure ratio and output of the WIWA DUOMIX system, high-viscosity materials can be applied without difficulty. This allows a high coating thickness to be achieved in one pass, saving the time which would be necessary to apply additional coats.

Through the use of automatic WIWA material refill systems, downtime due to replacing depleted drums/containers is eliminated and spraying can proceed without interruption.

Labor costs are also reduced, as each component in the system is transferred separately. Less work is necessary for cleaning, since only those parts which come in contact with mixed material must be flushed.

Reduction in Costs Due to Curing Time, Storage and Downtime

Through the use of high-viscosity materials with a short potlife, docking and operational costs in shipyards can be reduced.

Shorter downtime periods for coating structures such as silos, sewage facilities, parking houses, cooling towers and pipelines.

Short curing times reduce the costs of storage and processing in most fields of application.

In the construction of large vehicles, such as railroad and tank cars, operational costs, as well as the downtime incurred when conducting maintenance, are reduced.

Costs for the acquisition and operation of drying facilities and curing ovens are reduced considerably.

The Environment

Hazardous waste is reduced through the use of large recyclable containers (no more paint cans with residual material needing disposal).

Through the use of WIWA DUOMIX units, no solvents are necessary to apply coating materials.

Disturbing odors are held to a minimum during the spraying and curing phases.

Spray fog is kept to a minimum, as no solvents are used for spraying.



A railcar for transporting food is being coated with a solvent-free, thick polyurethane coating using a WIWA DUOMIX 333 (solids: 92,5%, potlife: 5 minutes, spraying temperature: 60°C).

GICAL



Here, an **icebreaker** is being sprayed with a special coating material (potlife: 5 minutes, spraying temperature: 55°C) using a WIWA DUOMIX 333 with heated hoses.



Ship Building

The WIWA DUOMIX has enjoyed world-wide success in the ship building industry for two and three component applications, such as block, ballast tank, outer hull and deck coatings.

Railcar Industry

Solvent-free and water-based coating materials have prevailed in respect to coatings for railcars and other large vehicles.

Pipe and Tank Coatings

The WIWA DUOMOIX systems have proven their value in these especially demanding fields of coating application.

Pipeline Maintenance

Due to its robust nature, the WIWA DUOMIX can be effectively used in remote terrain environments and has proven successful in various pipeline maintenance projects.

- Wide range of available performance ratings
- Designed according to individual requirements
- Shorter curing times
- Reduction in material and labor costs
- Environmentally friendly

Many of today's tank coatings call for dual component coating materials with an extremely short pot-life (ie. 30 seconds).

WIWA DUOMIX High-Performance Spraying Equipment – The reliable system for the large variety of plural component coating materials

ADVANTAGES OF THE DU

Years of experience, a sophisticated concept and a high-caliber, robust design are typical traits of WIWA quality.

WIWA DUOMIX – probably the only dual component system world-wide which combines the flexibility of a variable mixing ratio and the security of a fixed ratio system, in addition to being able to process three component applications.

Requiring little work at all, the center hardener pump can be exchanged to achieve almost any mixing ratio between 1:1 and 8:1 (incl. decimal values, such as 5,6:1).

The time-consuming litering and adjusting necessary for other dual component systems is eliminated, as well as the unintentional alteration of the mixing ratio's setting.

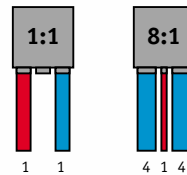

Output per cycle	up to 700 ccm
Pressure ratio	up to 85:1
Mixing ratio	from 1:1 to 8:1

Principles of the DUOMIX System

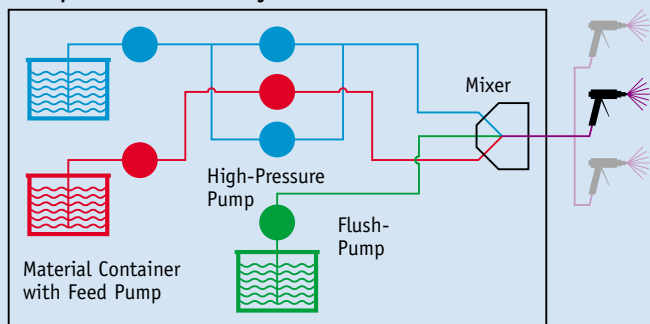

The high-pressure pump ensures that the exact dosage of each coating material component (base and hardener) is dispensed into the mixing block and then led to the spraying gun.

When preparing to flush the system, mixed material still located in the spraying hoses can still be applied due to the high-pressure ratio of WIWA's flush pumps.

The Application Determines the Design.

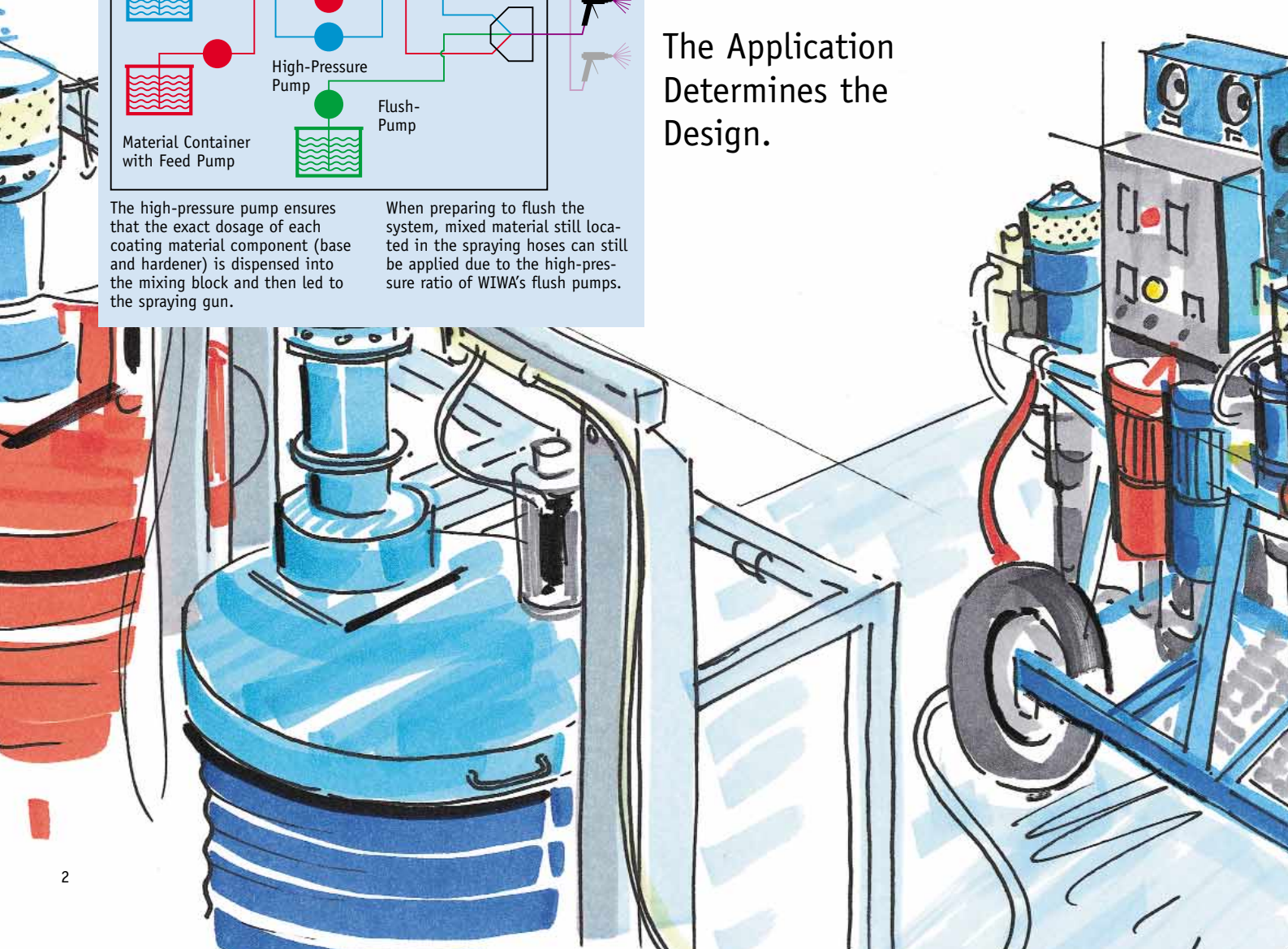

DUOMIX CONCEPT

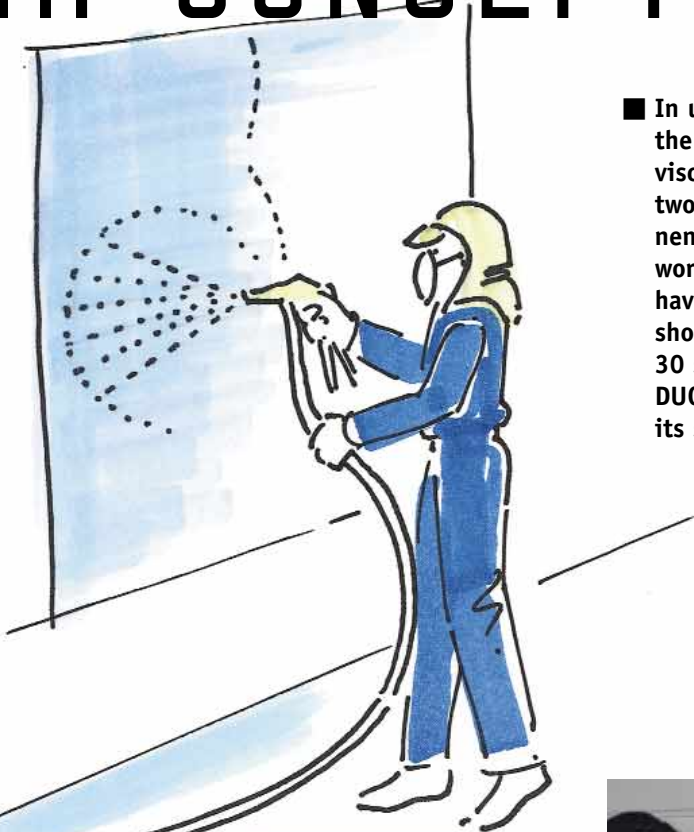

■ In use world-wide for the processing of high-viscosity, solvent-free two and three component materials. When working with materials having an extremely short potlife (i.e. 30 seconds), the WIWA DUOMIX best exhibits its strengths.

■ The main fields of application are the marine and offshore oil industries, tank and container construction, pipe and pipeline coatings, coatings for railcars and other large vehicles, protection and sanitation of steel structures, and other large surface area coatings, such as silos, cooling towers and sewage plants.

■ A wide range of performance ratings for all high-, middle- and low-viscosity dual component coatings is available.

■ Even at low ambient temperatures, perfect coating results are assured through the use of various heating systems.

■ As a result of its special conception, the WIWA DUOMIX Dual Component System can also be used in applications requiring three components.

■ Due to the modular design of the WIWA DUOMIX, a nearly boundless variety of solutions is achieved and each system is configured reflecting the individual requirements of the customer.

If desired, every WIWA DUOMIX system can be delivered with a measurement device to show the flow rate of each component or to monitor the mixing ratio and, if required, to print a record of the results.



Here, pipes were sprayed with a polyurethane coating material (potlife: 30 seconds, spraying temperature: 55°C) using a WIWA DUOMIX 300.

In the area of pipeline maintenance, a potlife within the range of 5 - 30 seconds is common.

The conception and quality of each component guarantee a perfect system: **WIWA DUOMIX** High-Performance Spraying Equipment

ELEMENTS OF PERFECTI

The basic elements of a WIWA DUOMIX system are the proportioning unit with the pressure and metering monitor, the material pump combination for the specified application, the feed pumps, a flush pump and a mixing block.

WIWA – Technology at its highest standard!

The high art of simplicity is made evident in the reliability, durability and longevity of WIWA's products.

The user-friendly maintenance plan is an additional WIWA plus.

Dual Component High-Pressure Pump

- The dual component high-pressure pump is the heart of every WIWA DUOMIX High-Performance Spraying System. The wide variety of available performance ratings, high level of quality and robust design set it above the competition.
- Outputs per cycle up to 700 ccm
- Pressure ratios up to 85:1
- Mixing ratios from 1:1 to 8:1
- Extremely high level of dosage accuracy
- A potlife of a few seconds can be worked with effectively
- Depending upon the material pumps used, the WIWA DUOMIX can also be configured to spray low- or medium-viscosity coating materials, such as zinc primer

The WIWA DUOMIX can also be adapted for three component applications.

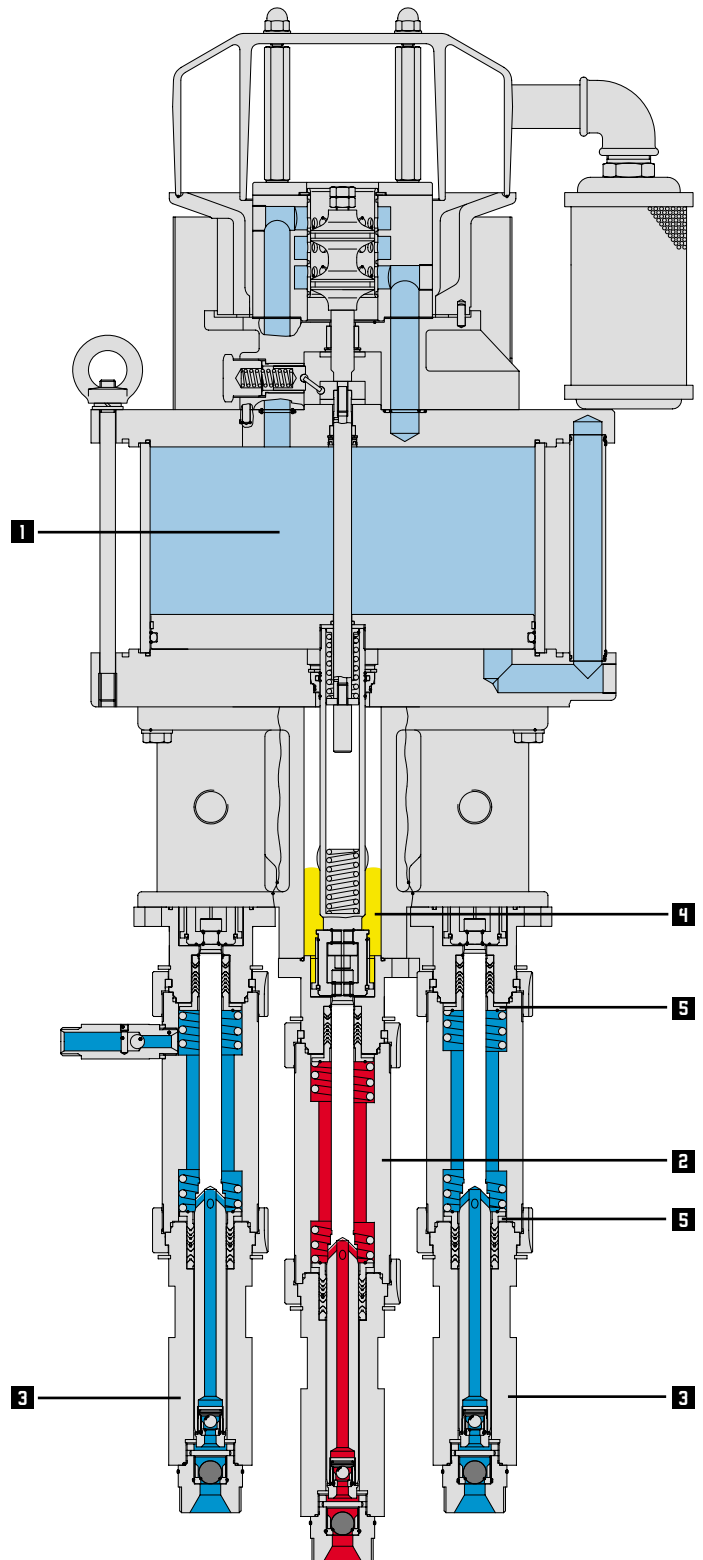

ON ...

Air Motor

- 1 The patented air motor is equipped with a unique de-icing system and robust maintenance unit. Its piston rod is guided by two axles which lead into the upper and lower housings. This ensures tilt-free operation of the three material pumps which are connected directly to the same piston plate, and reduces wear and tear on the packings and piston rod.

Material Pump Combination

- 2 By simply exchanging the center hardener pump, a new mixing ratio can be achieved quickly and effectively.
- 3 Should new applications require different performance ratings, these can also be achieved by exchanging the material pumps.
- 4 A closed lubrication chamber separates the air motor from the material pumps. The lubricant prevents paint from crusting onto the piston rod and protects the packings.
- 5 All material pumps are equipped with fixed, spring supported, self-adjusting packings.



Pressure and Metering Monitor

To avoid any mixing ratio errors, the pressures of both components are monitored by means of two contact pressure gauges.

Should WIWA's recommended tolerance settings for the maximum and/or minimum pressure be surpassed, the system shuts down automatically.

WIWA's standard incorporation of rupture discs into the system prevents operation above the maximum allowable working pressure and possible damage as a result.

Simple operation by means of large, practical, easy to find control switches. The pressure levels can be easily read on the large pressure gauges.

Since the entire system, including the pressure and metering monitor, is operated pneumatically, the WIWA DUO-MIX is explosion-proof (unless non-explosion-proof devices, such as heating elements or other electrical components are added to the unit).



Technical Training for International Personnel

... FOR YOUR INDIVIDUAL



- Hose heaters (heated electrically or with hot water).
- Drum floor heaters or heating belts.
- Water-heated containers (70 liters).



Heating Systems

For constant low ambient temperatures, high-viscosity materials and coatings requiring high working temperatures, WIWA offers a variety of heating solutions:

- Explosion-proof, low-pressure fluid heaters for the material supply.
- Explosion-proof, high-pressure fluid heaters (3,5 kW), authorized for use up to 450 bar, for the high-pressure area.

Feed Pumps and Supply System

As dual component materials used for anti-corrosion coatings tend to be very high in viscosity and have up to a 100% solids content, the dual component system has to be force-fed.

Depending upon the viscosity and output required, WIWA incorporates pneumatically driven diaphragm or piston feed pumps into the DUOMIX system to accomplish this.

For materials which can only be supplied in small containers (25 – 30 liter pails), we recommend the use of filling funnels.

The automatic refill system for 200 liter drums, composed of twin-post lifts with feed pumps, a drum level indicator and an automatic refilling assembly, ensures interruption-free operation.

Flush Pump

Designed to rinse all system components which come in contact with the mixed material being sprayed.

For short hose lengths, we recommend using a flush pump with a 32:1 pressure ratio and an output of 72 ccm per cycle.

For longer hose lengths, flush pumps with a higher pressure ratio and output should be used, such as 66:1 with an output of 72 ccm per cycle or 64:1 with an output of 158 ccm ccm per cycle.



Every WIWA DUOMIX System is configured using modern CAD technology to reflect the individual application needs of each customer.

SYSTEM!



Mixing Block

WIWA mixing blocks are pneumatically controlled and include a flushing arrangement and static mixer.

Reliable pneumatic valves (with tungsten carbide valve seats and balls) replace interference-prone ball valves.

Releasing and/or bleeding the pressure in the system to provide circulation during interruptions in work is also achieved by way of pneumatic valves.

If desired, the mixing block can also be delivered with hand-operated valves.

The mixing block is frame-mounted for applications with materials having a long pot-life. For those applications which have a short or extremely short pot-life, an external mixer is available which can be located directly where the coating is being applied.

If required, the system can be configured for operation with a remote control, as well.



Dosage Control and Dispensing Station

The mixing ratio can be checked using this assembly.

Furthermore, a small quantity of each component can be dispensed in amounts corresponding to the mixing ratio. These materials may then be mixed manually for making light touch-ups, which is very advantageous.

No additional cleaning is necessary, as each component is dispensed separately.

- **Explosion-proof, pneumatic system**
- **Pressure and metering monitor for both components with automatic shut-down function**
- **High resistance to wear and tear, due to the tilt-free operation of the material pumps**
- **Various heating systems for differing application needs**
- **If desired, a more powerful flush pump is available to ensure that mixed material can be applied, even at longer hose lengths**



A complete WIWA DUOMIX Dual Component Unit, including an automatic drum refill system for both the base and hardener components, is integrated in a container, providing security, mobility and a maximum utilization of space. This enables the operator to quickly change locations within the wharf or on a shipdeck. Furthermore, the system is protected against climatic influences, as well as unauthorized access.

MODULAR SOLUTIONS

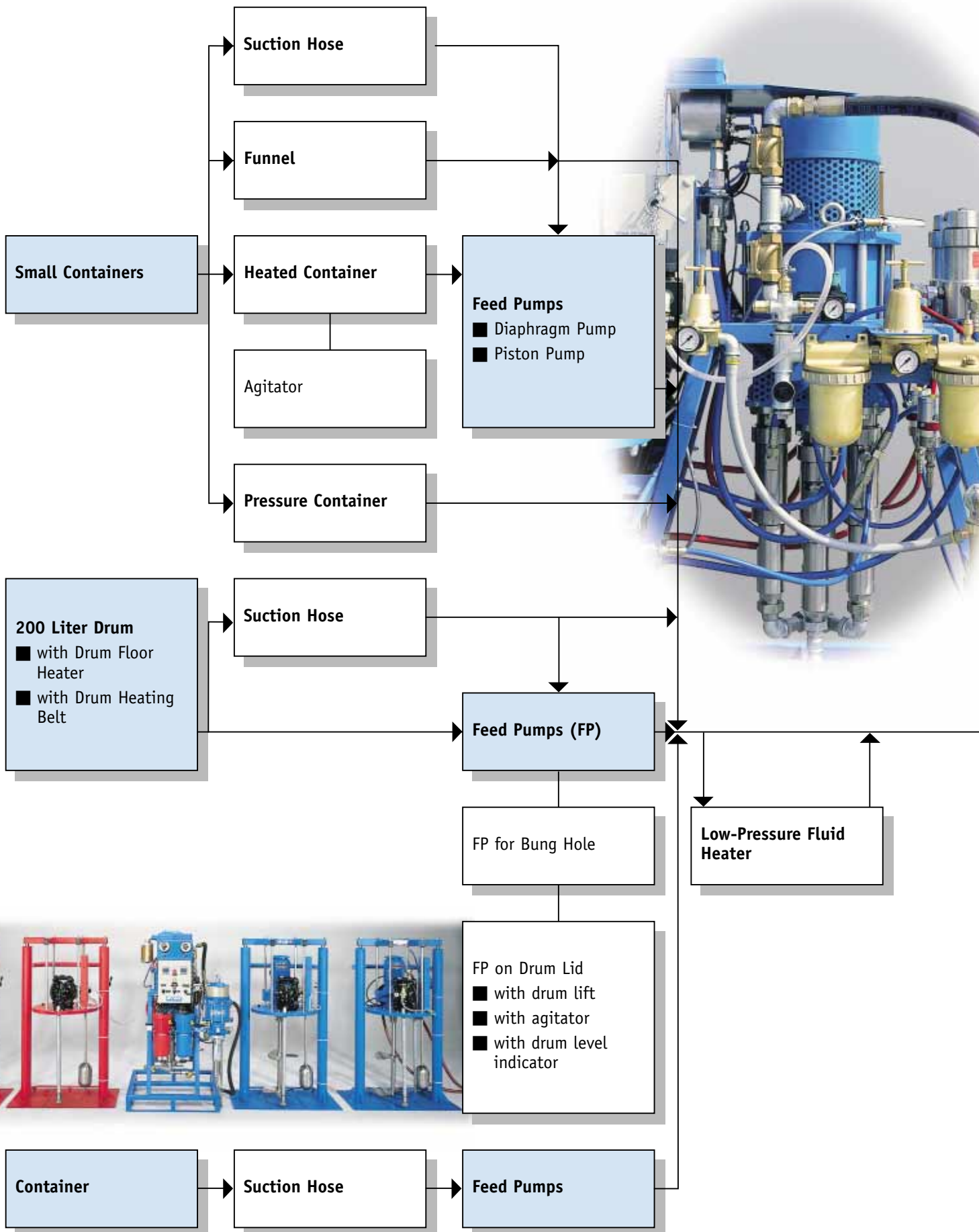

The Optimal Design and Configuration for Every Application

Starting with the supplied containers of coating material and ending at the airless spraying guns, the variety of

performance ratings achieved through the modular design of the WIWA DUOMIX is nearly limitless.

Modular Design. The design of the WIWA DUOMIX system corresponds to the requirements of the material being sprayed, as well as the area of application.

Depending upon the application, the WIWA DUOMIX can either be designed as a single, stationary unit or be broken down into modular units located in different areas.

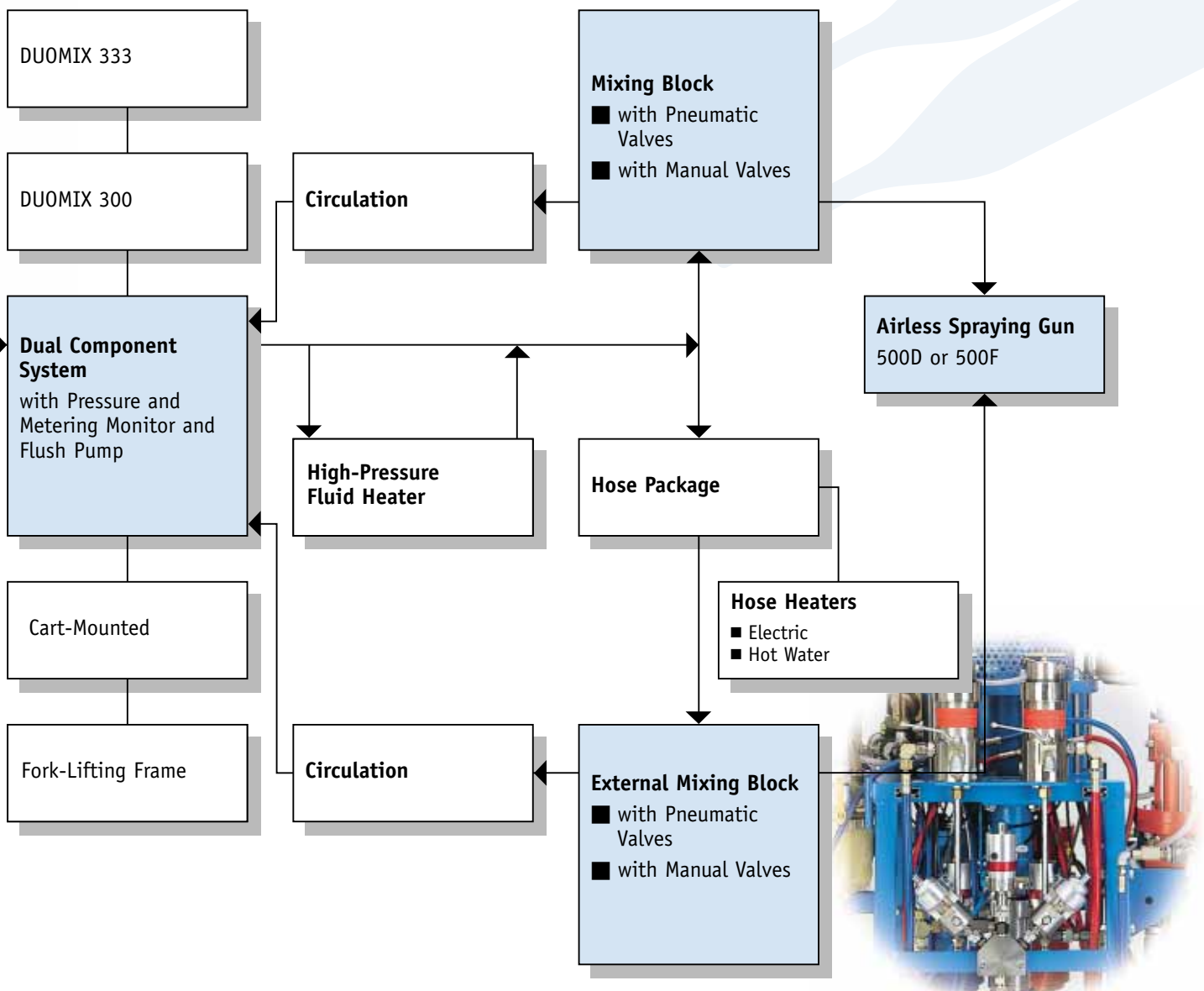
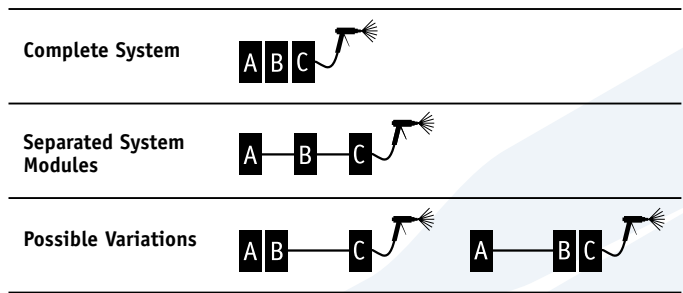
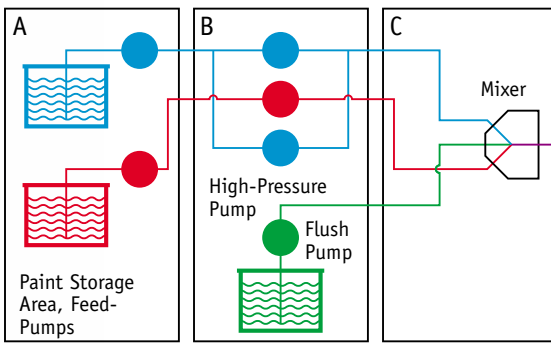

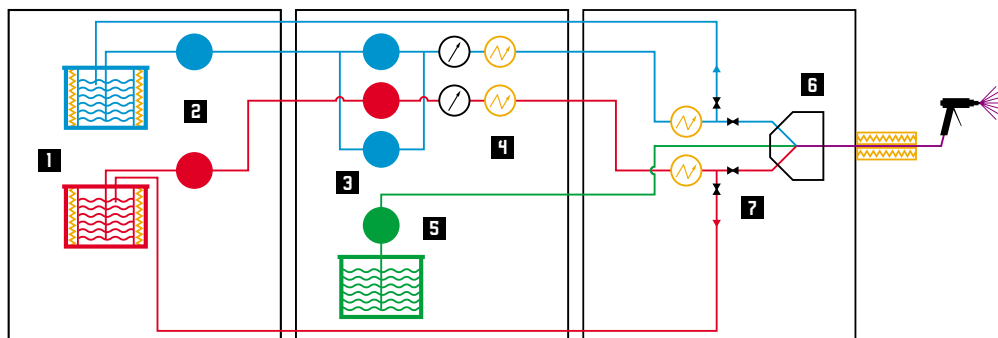

WIWA DUOMIX SERIES 30

Example of a Complete WIWA DUOMIX High-Performance Dual Component Spraying System



- 1** Heated container (with agitator, if desired)
- 2** Feed pumps (diaphragm or low-pressure piston pumps)
- 3** Proportioning unit with three material pumps
- 4** WIWA fluid heater

- 5** Flush pump for thorough cleaning
- 6** Mixing block with static mixer and flushing assembly
- 7** Pneumatic valves for releasing and/or bleeding system pressure

-  Heating System
-  Contact Pressure Gauges

Individual Solutions Derived from Standardized Sub-assemblies:

WIWA custom designs each DUOMIX High-Performance Spraying System using primarily standardized components to fit the exact needs of the intended application. This results in a system which is optimized for your individual requirements, providing the highest performance level at the lowest possible cost. This is accomplished while maintaining the known quality of WIWA engineering under continual use. The fact that standard components are used also ensures a ready supply of compatible spare parts.



These pictures show the clear arrangement of all components and the easy to operate control box of the WIWA DUOMIX system.



Basic System Includes:

- WIWA high-pressure pumps, proven quality at its highest standard.
- Robust frame for mounting all components.
- Air maintenance unit "R1" complete with all fittings.
- High-pressure filter for both base and hardener.
- Safety device (rupture discs) for base and hardener in system areas under high pressure.
- Pneumatic mixing block with static mixer and flushing arrangement, as well as a material outlet (3/8" NPT). Reliable pneumatic valves (valve seats and balls of tungsten carbide) replace interference-prone ball valves.
- Pressure release/drain (circulation) by way of two pneumatic valves.
- Complete pressure and dosage monitoring for each component with automatic shut-down should the tolerance settings be surpassed.
- Flush pump for rinsing all components which come in contact with mixed material (pressure ratio: 32:1, output per cycle: 72 ccm).
- Anti-freeze unit for the air motor.
- Muffler.

Optional Accessories

- Pneumatically operated diaphragm or piston feed pumps.
- Explosion-proof WIWA fluid heater with a rating of 3,5 kW (adjustable range from 20 – 85°C).
- Pneumatic stroke counter for volume control.

■ **Compact design on a robust cart or fork-lifting frame**

■ **Components arranged to provide for a clear overview and easy servicing**

■ **Sophisticated valve and safety technology**

■ **Diverse feed and heating systems**

■ **Simple to use**



WIWA Duomix Dual Component System with fork-lifting frame and automatic drum refill system for 200 liter drums.

For each component, two lifts with feed pumps and drum level indicators are used.

The automatic refill system located next to the pump ensures that each feed drum is refilled from a second drum behind it, ensuring continuous operation.

The drum level indicator of the second drum produces an acoustic signal when the drum has to be exchanged.

For base materials with high solids content, it is recommended to use lifts with an additional agitator for the drums which will be exchanged.

A plus on safety

To ensure that no confusion takes place between individual system components which come in contact with either base or hardener (i.e. fluid hoses, fluid heaters), these items are color coded (**blue** for the base material, **red** for the hardener) or marked accordingly.

OPTIONAL WIWA DUOMIX

Feed Systems

For the supply and/or force-feed of material to the WIWA DUOMIX Dual Component System, various feed pumps are available.



Piston Pumps

Model	150.05,5	375.05	600.06
Pressure Ratio	5,5:1	5:1	6:1
Output per Cycle (ccm)	150	375	600
Max. Air Inlet Pressure (bar)	8	8	8
Max. Operating Pressure (bar)	44	40	48

Further low-pressure piston pumps are available upon request.

The piston pump model 150.05,5 is also suitable for use with a bunghole, due to its diameter. All pumps are available in N (non-stainless steel) or RS (stainless steel) versions.

Diaphragm Pumps

Technical Details

Pressure Ratio	1:1
Max. Output	178 liters/min.
Max. Operating Pressure	8 bar

Material Feed Arrangements

In addition to the feed methods already mentioned (feed pumps, heated containers, etc.), the spraying material can also be fed by way of suction hoses, funnels or direct from large containers (tanks).

Flush Pumps

Depending upon the exact application, WIWA offers a variety of flush pumps (high-pressure pumps).



Model	10032	10066	28064
Pressure Ratio	32:1	66:1	64:1
Output per Cycle (ccm)	72	72	153
Max. Air Inlet Pressure (bar)	8	6,5	7
Max. Operating Pressure (bar)	256	429	450

All above pumps are available in N (non-stainless steel) or RS (stainless steel) versions.

Heating Systems



1. Fluid Heaters

WIWA offers low- and high-pressure fluid heaters to heat each individual component to the working temperature which is required by the coating manufacturer. All fluid heaters are explosion-proof. Inside the high-pressure fluid heaters, the parts which come in contact with the material being heated are made of stainless steel.

Technical Details

Model	3500 HD	3500 ND
Nominal Power (Watt)	3500	3500
Max. Operating Pressure (bar)	450	250
Temperature Range (in °C)	20-85	20-85

All fluid heaters are available in 230V (16A), 380V (10A) and 440V (8A) versions.

2. Drum Floor Heaters

Drum floor heaters are designed for heating coating materials supplied in 200 liter drums. This is especially advantageous, as the material is heated where it is pumped.

Model	B0200	B0200ex
Nominal Power (Watt)	1500	950
Voltage (Volts)	230	230
Temperature Range (in °C)	50-300	50-300
Explosion-Proof	No	Yes

3. Drum Heating Belts

Drum heating belts are placed around 200 liter drums to heat them from the sides. Depending upon the desired temperature of the material, it may be necessary to use one or more belts.

Power (Watt)	1000
Voltage (Volts)	230
Explosion-Proof	No

4. Heated Container

For materials which are only available in small containers, we recommend using WIWA's explosion-proof, water-heated containers. Each container is capable of holding up to 70 liters of material.

Power (Watt)	3500 and 7000
Temperature Range (in °C)	20-85



5. Hose Heaters

For long hose lengths and materials which have to be sprayed at high temperatures, the spraying hoses must be heated. For this purpose, WIWA offers both electrical and hot water systems. The exact version required depends upon the application and the characteristics of the material being processed.

ACCESSORIES



Agitators



Dual component materials often have a very high solids content, so it is generally necessary to use agitators. WIWA offers a broad spectrum of electric and pneumatic agitators depending upon the application and the type of material containers supplied.

Drum Agitator for 200 Liter Drums

Pneumatic or Electric	p	e	e	e
Power (Watt)	1,1	0,37	0,75	2,5
Voltage (Volts)	N/A	400	400	400
Explosion-Proof	yes	yes	yes	yes
RPM's	214	98	120	80

Manual agitators and agitators for 1000 liter containers (tanks) on request.

Lifting Platforms



To lift drum lids mounted with feed pumps and agitators, we recommend the use of the pneumatically driven WIWA single- and/or twin-post lifts.

Model	Max. Lifting Capacity	Max. Air Inlet Pressure
Single-Post Lift	375 kg	116 bar
Twin-Post Lift	750 kg	116 bar

Dosage Control and Dispensing Station



This assembly allows a small quantity of each component to be dispensed in an amount corresponding to the mixing ratio. These materials may then be mixed manually for touch-ups, which is very advantageous. No additional cleaning is necessary, as each component is dispensed separately.

Frame

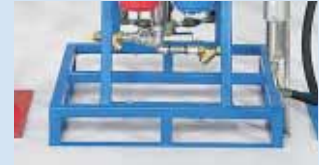

The WIWA DUOMIX Dual Component Spraying System can be delivered mounted on a robust cart or on a compact fork-lifting frame.

Mixing Block



Depending upon the potlife of the material being sprayed and the hose lengths required, the mixing block can either be mounted on the frame of the proportioning unit or be externally located, directly where the spraying is taking place. Versions are available with either manual or automatically operated valves.

The external mixing block with automatic valves can also be equipped with a remote control, enabling the sprayer to operate the mixing block himself.

Drum Level Indicator



In order to achieve interruption-free operation of the WIWA DUOMIX Dual Component Spraying System, either a pneumatic or electric drum level indicator should be installed to monitor the amount of material remaining in each drum. When using the WIWA automatic drum refilling system, the feed drum is refilled automatically from a second drum once the level indicator registers that the minimum point has been reached.

Flow Meters



To measure the rate of flow of each component or to monitor the mixing ratio, various flow meters are available. The flow meters can be fitted with electronic analysis equipment, interfaces and printers to provide a written record of the measurement results.



**Spray Technology
Fluid Handling**

WIWA

Wilhelm Wagner GmbH & Co. KG
Gewerbestraße 1-3
P.O.B. 29
35631 Lahnau, Germany

E-mail: info@wiwa.de
Internet: http://www.wiwa.de

Telephone +49 (64 41) 6 09-0
Telefax +49 (64 41) 6 09-50/-58

FAST PER FAX

Experience and versatility are the basis of success.

50 years of experience in the field of spray technology, coatings and fluid handling, as well as excellent service, ensure overall security for WIWA's customers.

Continuous development and the extensive know-how of WIWA's qualified employees make the versatility of the WIWA program possible.

Get to know WIWA's wide range of products:

- WIWA PROFIT – portable, low-cost spraying equipment for trade and industry
- WIWA PHOENIX – the new series for trade and industry with maximum performance and minimum costs
- WIWA SUPER – well-known for its ruggedness and durability
- WIWA PROFESSIONAL – the new series for heavy corrosion protection with an especially diverse program for all sorts of industrial coatings

- WIWA HERKULES – the new high-performance series for heavy corrosion protection and the marine industries
- WIWA DUOMIX 140/230 – compact and versatile plural component spraying systems for paint or foam applications
- WIWA AIR COMBI – for extremely fine finishes using the environmentally friendly Air-Combi technology
- WIWA Hot Job spraying equipment – fast curing, fantastic surfaces
- WIWA ZINC SILICATE – special airless spraying equipment for water – or solvent-based zinc silicate coatings
- WIWA Extrusion Pumps
- WIWA Injection equipment for structural preservation
- WIWA Low Pressure Pumps for the handling of all materials capable of flowing
- Specially designed equipment based on each customer's specific needs

Name _____

Company _____

Street _____

Postal Code/Town _____

Phone _____

Fax _____

E-mail _____

Date _____

I am interested in WIWA products. I request:

- Information on the equipment marked at the left.
- Your complete catalog.
- An appointment for a personal consultation.
- Information on equipment suited for my application(s):

We would be pleased to provide you with a detailed offer covering all WIWA equipment and related accessories.

Your local distributor is: