

PU - Pistole  
PU - gun  
PU - pistolet  
4040 - automatic

Bestell-Nr. • Order-No. • Référence: **0666844**  
Serie • Serie • Série: **001**  
Datum • Date • Date: **14.12.2023**

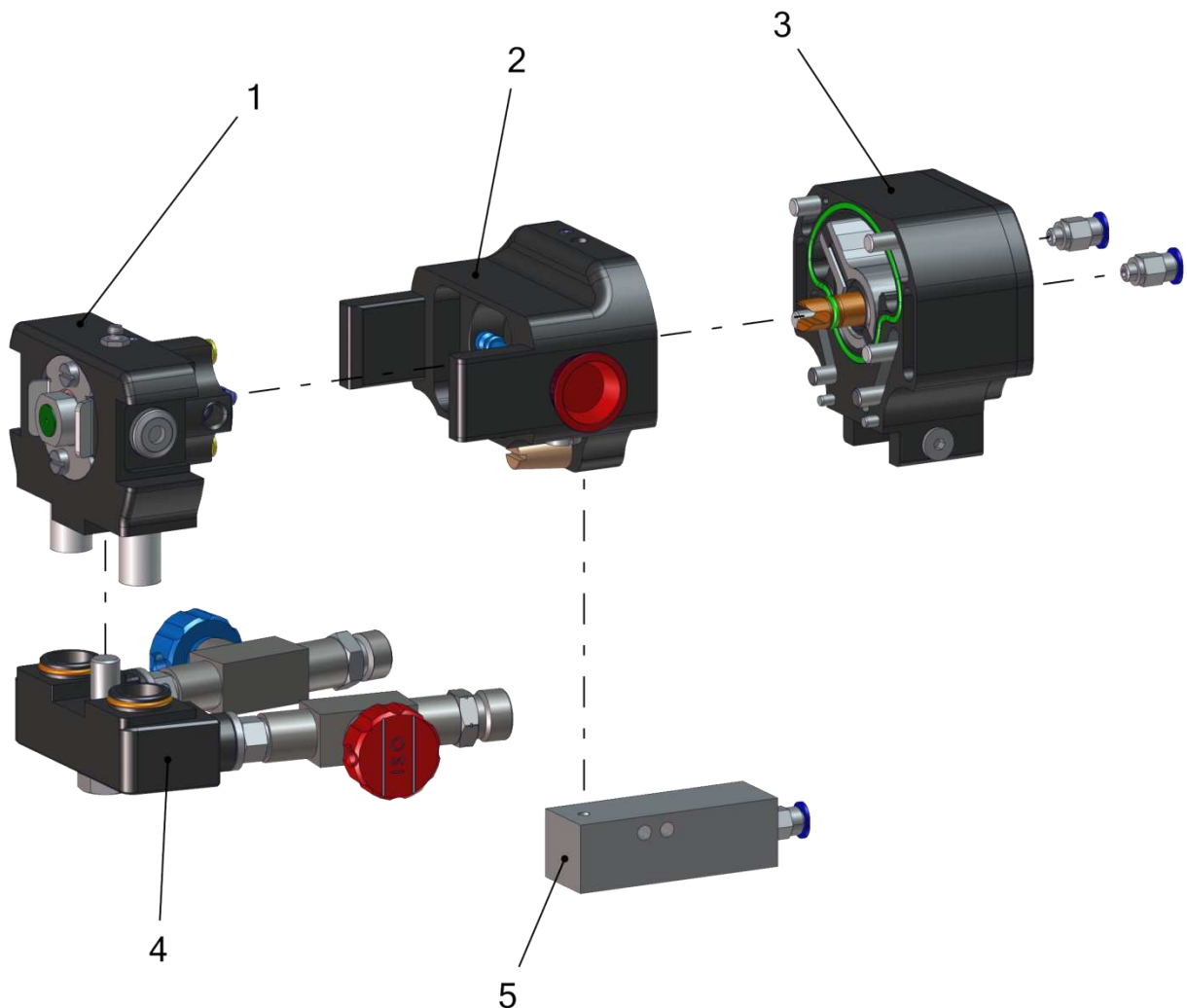

Pos.-Nr. in Klammern () sind keine Bestandteile dieser Baugruppe / items marked with () are not part of assembly shown / Les pièces entre parenthèses ne font pas partie du sous-groupe

Diese Zeichnung darf nicht kopiert, vervielfältigt oder dritten Personen zugänglich gemacht werden. Widerrechtliche Benutzung hat strafrechtliche Folgen. / This drawing should not be, in whole or in part, copied, distributed or used by or passed on as information to others for competition purposes or for whatever purposes without authorization. Unauthorized use is subject to prosecution.

**Hauptsitz und Produktion / Headquarter & Production**

**WIWA Wilhelm Wagner GmbH & Co. KG**  
Gewerbestraße 1-3 • 35633 Lahnau, Germany  
Tel: +49 6441 609-0 • Fax: +49 6441 609-50  
E-Mail: [info@wiwa.de](mailto:info@wiwa.de)  
Internet: [www.wiwa.de](http://www.wiwa.de)

**WIWA Subsidiary USA**

107 N.Main St. • P.O.Box 398, Alger, OH 45812  
Tel: +1-419-757-0141 • Fax: +1-419-549-5173 •  
Toll Free: +1-855-757-0141  
E-Mail: [sales@wiwa.com](mailto:sales@wiwa.com)  
Internet: [www.wiwausa.com](http://www.wiwausa.com)

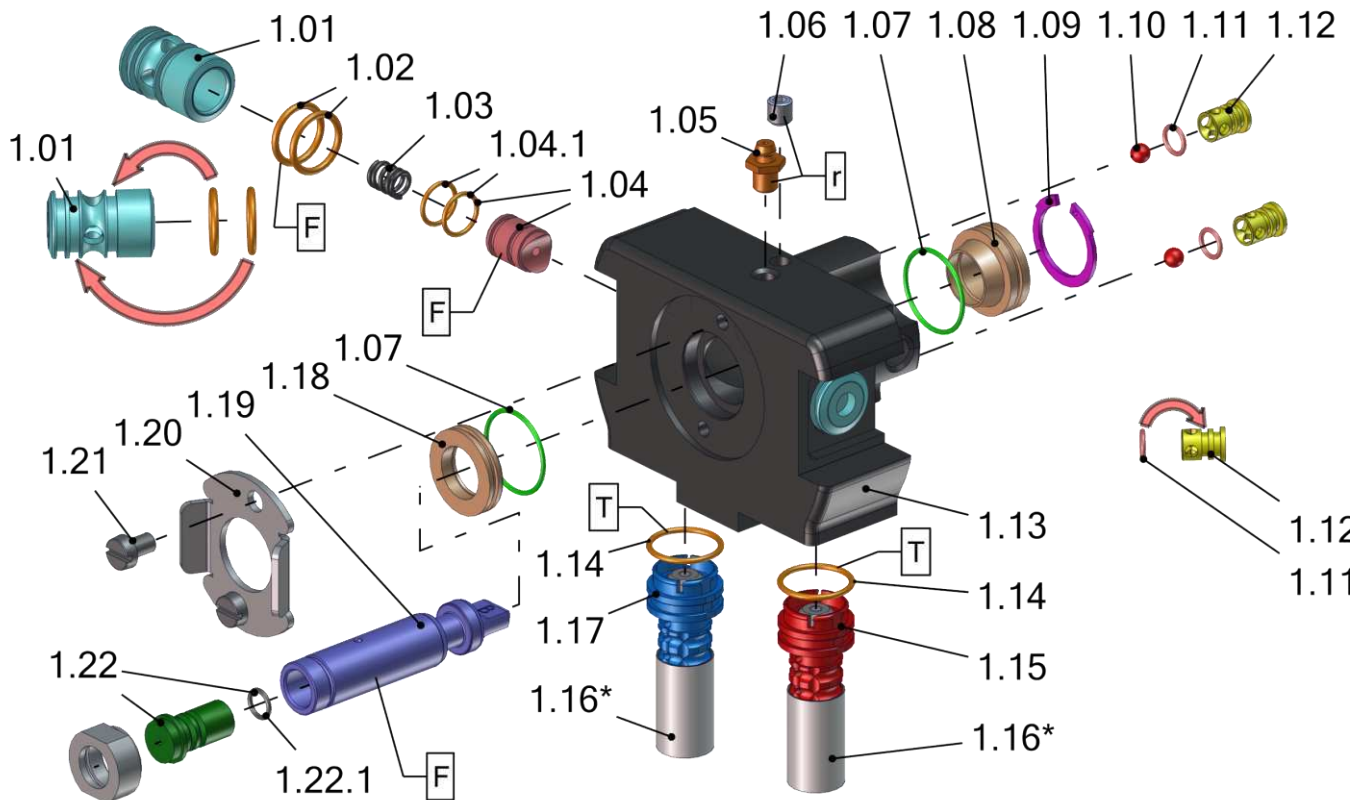

Pos.	Number	Qty.	V <sup>1</sup> /D <sup>2</sup> /R <sup>3</sup>	Artikelbezeichnung	Part Description	Désignation des articles
1.01	0664952	2		Druckstück	spring disc	membre de pression
1.02	0657604	4	V, D	O-Ring	o-ring	joint torique
1.03	0666504	2	V	Druckfeder	spring	ressort
1.04	0666745	2	V, D	Anpressdichtung kpl.	press seal cpl.	joint cpl.
1.04.1	0658264	2	V, D	O-Ring	o-ring	joint torique
1.05	0652469	1		Schmiernippel	grease nipple	raccord fileté de graissage
1.06	0460702	1		Gewindestift	threaded pin	vis sans tête
1.07	0660834	2	V, D	O-Ring	o-ring	joint torique
1.08	0656574	1		Führungsring	guide ring	guidage
1.09	0657605	1		Sicherungsring	retaining ring	circlip
1.10	0645138	2		Kugel	ball	bille
1.11	0668825	2	V, D	O-Ring	o-ring	joint torique
1.12	0658761	2		Gehäuse	housing	logement
1.13	0665432	1		Pistolenkörper	gun body	corps de pistolet
1.14	0668827	2	V, D	O-Ring	o-ring	joint torique
1.15	0665443	1	V	Rückschlagventil	non-return valve	soupape de non-retour
1.16*	0656916	2	V	Sieb - Pistolenfilter	sieve	passoire
1.17	0665444	1	V	Rückschlagventil	non-return valve	soupape de non-retour
1.18	0656588	1		Führungsring	guide ring	guidage
1.19	0656909	1	V	Mischkammer kpl.	mixing chambre cpl.	chambre de melange cpl.
1.20	0665437	1		Adapterblech	adaptor	adaptateur
1.21	0474754	2		Schraube	screw	vis
1.22	0658504	1	V	Einsatz	insert	insertion
1.22.1	0668825	1	V, D	O-Ring	o-ring	joint torique

**Hauptsitz und Produktion / Headquarter & Production**

WIWA Wilhelm Wagner GmbH & Co. KG  
 Gewerbestraße 1-3 • 35633 Lahnau, Germany  
 Tel: +49 6441 609-0 • Fax: +49 6441 609-50  
 E-Mail: info@wiwa.de  
 Internet: www.wiwa.de

**WIWA Subsidiary USA**

107 N.Main St. • P.O.Box 398, Alger, OH 45812  
 Tel: +1-419-757-0141 • Fax: +1-419-549-5173 •  
 Toll Free: +1-855-757-0141  
 E-Mail: sales@wiwa.com  
 Internet: www.wiwausa.com

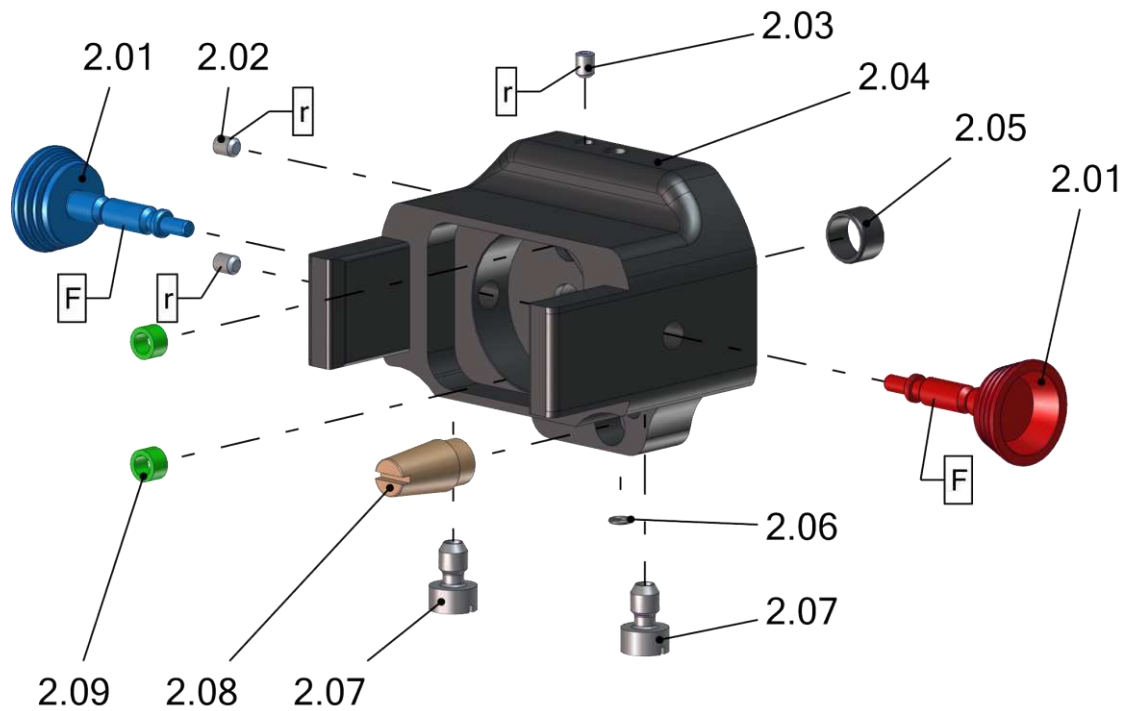

Pos.	Number	Qty.	V <sup>1</sup> /D <sup>2</sup> /R <sup>3</sup>	Artikelbezeichnung	Part Description	Désignation des articles
2.01	0656911	2		Sicherungsstift	retainer pin	pointe de sûreté
2.02	0491799	2		Gewindestift	threaded pin	vis sans tête
2.03	0460702	1		Gewindestift	threaded pin	vis sans tête
2.04	0665431	1		Gehäuse	housing	caracasse
2.05	0656973	1		Gleitlager	slide bearing	palier lisse
2.06	0656974	1	V, D	O-Ring	o-ring	joint torique
2.07	0656604	2		Druckstück	spring disc	membre de pression
2.08	0645247	1		Schalldämpfer	air muffler	silencieux
2.09	0657606	2	V, D	Dichtung	gasket	joint

**Hauptsitz und Produktion / Headquarter & Production**

WIWA Wilhelm Wagner GmbH & Co. KG  
 Gewerbestraße 1-3 • 35633 Lahnau, Germany  
 Tel: +49 6441 609-0 • Fax: +49 6441 609-50  
 E-Mail: info@wiwa.de  
 Internet: www.wiwa.de

**WIWA Subsidiary USA**

107 N.Main St. • P.O.Box 398, Alger, OH 45812  
 Tel: +1-419-757-0141 • Fax: +1-419-549-5173 •  
 Toll Free: +1-855-757-0141  
 E-Mail: sales@wiwa.com  
 Internet: www.wiwausa.com

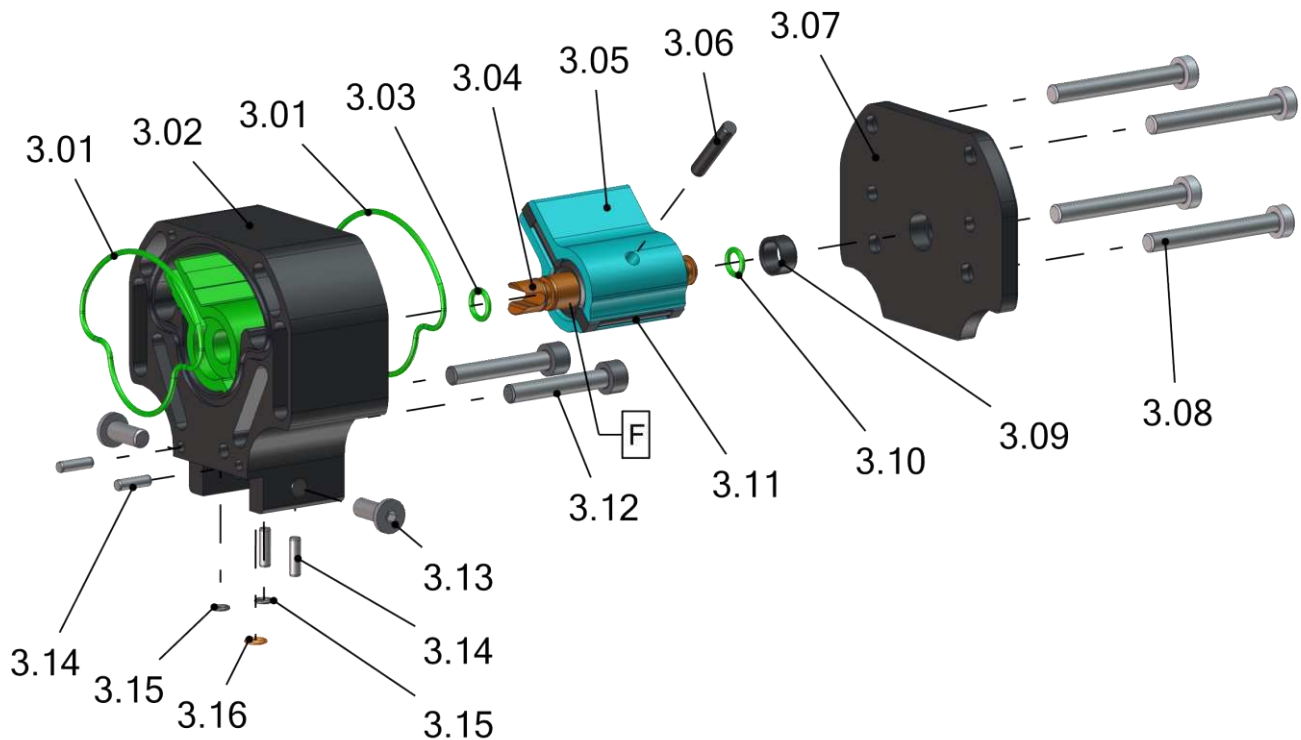

Pos.	Number	Qty.	V <sup>1</sup> /D <sup>2</sup> /R <sup>3</sup>	Artikelbezeichnung	Part Description	Désignation des articles
3.01	0657609	2	V, D	O-Ring	o-ring	joint torique
3.02	0665434	1		Gehäuse	housing	caracasse
3.03	0470392	1	V, D	O-Ring	o-ring	joint torique
3.04	0656906	1	V	Achse	axle	axe
3.05	0657601	1		Fahne	flag	drapeau
3.06	0657620	1		Zylinderstift	cylinder pin	goupille cylindrique
3.07	0656904	1		Deckel	cover	couvercle
3.08	0658313	4		Schraube	screw	vis
3.09	0656972	1	V	Gleitlager	slide bearing	palier lisse
3.10	0497657	1	V, D	O-Ring	o-ring	joint torique
3.11	0657602	1	V, D	Dichtung	gasket	joint
3.12	0414913	2		Schraube	screw	vis
3.13	0657608	2		Schraube	screw	vis
3.14	0650924	4		Zylinderstift	cylinder pin	goupille cylindrique
3.15	0656974	2	V, D	O-Ring	o-ring	joint torique
3.16	0665440	1	V, D	O-Ring	o-ring	joint torique

**Hauptsitz und Produktion / Headquarter & Production**

WIWA Wilhelm Wagner GmbH & Co. KG  
 Gewerbestraße 1-3 • 35633 Lahnau, Germany  
 Tel: +49 6441 609-0 • Fax: +49 6441 609-50  
 E-Mail: info@wiwa.de  
 Internet: www.wiwa.de

**WIWA Subsidiary USA**

107 N.Main St. • P.O.Box 398, Alger, OH 45812  
 Tel: +1-419-757-0141 • Fax: +1-419-549-5173 •  
 Toll Free: +1-855-757-0141  
 E-Mail: sales@wiwa.com  
 Internet: www.wiwausa.com



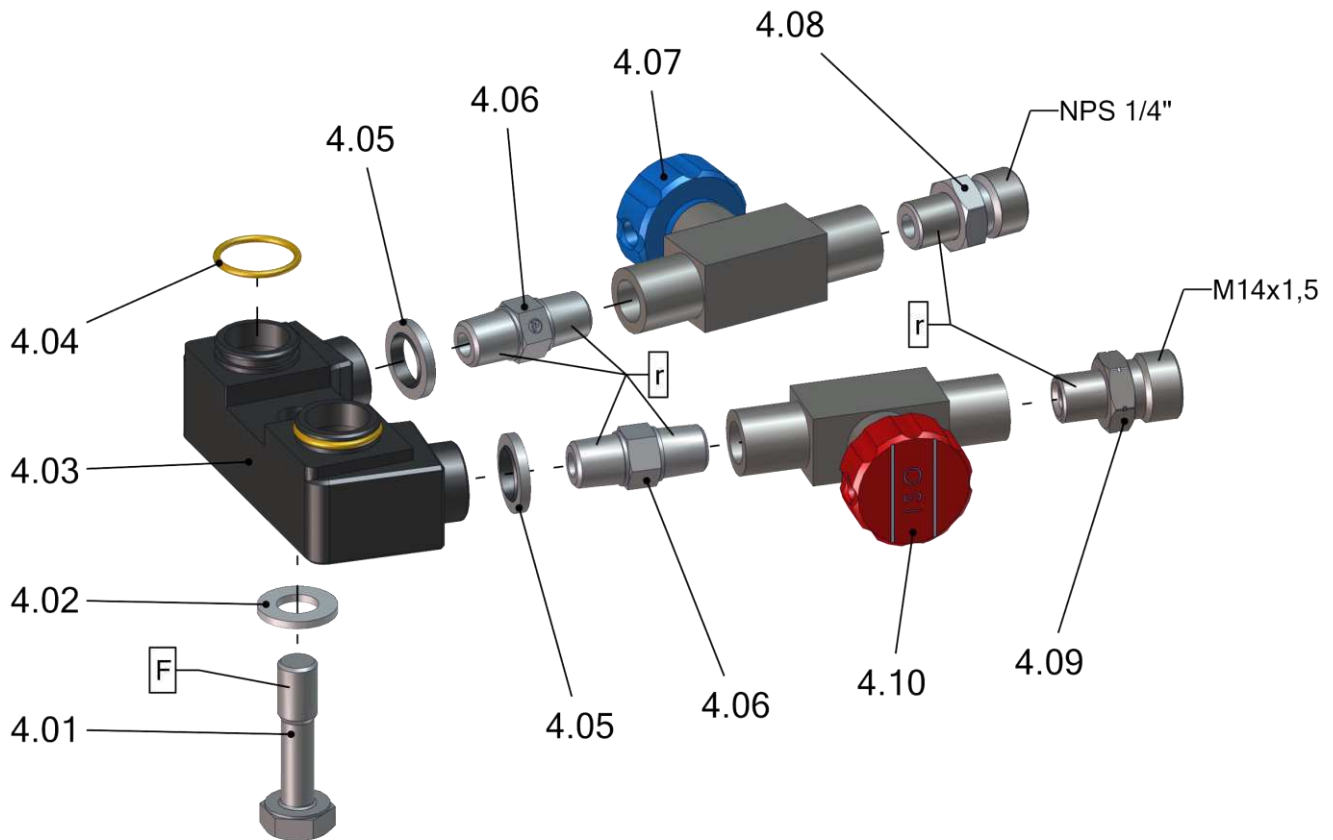

Pos.	Number	Qty.	V <sup>1</sup> /D <sup>2</sup> /R <sup>3</sup>	Artikelbezeichnung	Part Description	Désignation des articles
4.01	0657603	1		Schraube	screw	vis
4.02	0460214	1		Scheibe	washer	rondelle
4.03	0665433	1		Verteiler	manifold	distributeur
4.04	0661980	2	V, D	O-Ring	o-ring	joint torique
4.05	0658762	2	V	Usitring	gasket	joint
4.06	0656798	2		Doppelnippel	male adaptor	raccord double mâle
4.07	0658484	1	V	Kugelhahn kpl. Poly	ball valve cpl. Poly	vanne cpl. Poly
4.08	0656796	1		Doppelnippel	male adaptor	raccord double male
4.09	0654497	1		Einschraubverschraubung	screw fitting	vissage
4.10	0658503	1	V	Kugelhahn kpl. ISO	ball valve cpl. ISO	vanne cpl. ISO

**Hauptsitz und Produktion / Headquarter & Production**

**WIWA Wilhelm Wagner GmbH & Co. KG**  
 Gewerbestraße 1-3 • 35633 Lahnau, Germany  
 Tel: +49 6441 609-0 • Fax: +49 6441 609-50  
 E-Mail: info@wiwa.de  
 Internet: www.wiwa.de

**WIWA Subsidiary USA**

107 N.Main St. • P.O.Box 398, Alger, OH 45812  
 Tel: +1-419-757-0141 • Fax: +1-419-549-5173 •  
 Toll Free: +1-855-757-0141  
 E-Mail: sales@wiwa.com  
 Internet: www.wiwausa.com

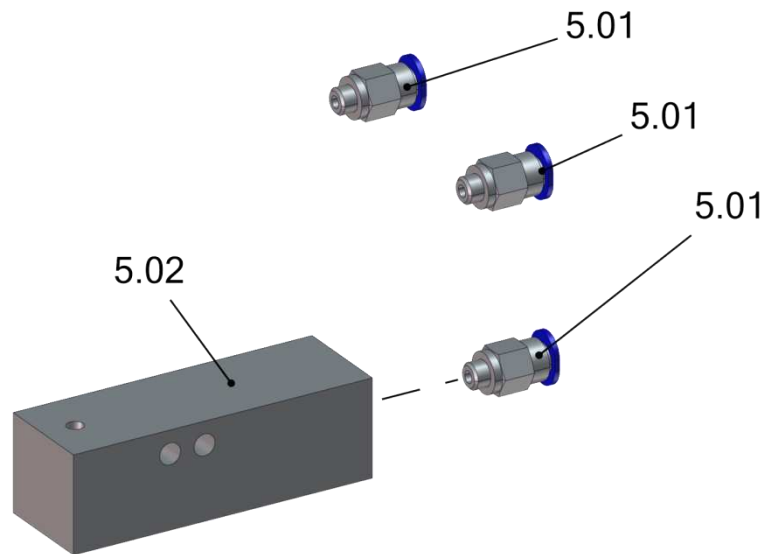

Pos.	Number	Qty.	V <sup>1</sup> /D <sup>2</sup> /R <sup>3</sup>	Artikelbezeichnung	Part Description	Désignation des articles
5.01	0634738	3		Steckverschraubung	plug-type fitting	vissage à fiche
5.02	0658141	1		Adapter	adaptor	adapteur

**ohne Abbildung - not illustrated - sans illustration**

Number	Qty.	V <sup>1</sup> /D <sup>2</sup> /R <sup>3</sup>	Artikelbezeichnung	Part Description	Désignation des articles
0667000			Dichtungssatz	seal kit	jeu de joints

**\*Sieb für Pistolenfilter / \*sieve for gun filter / \*passoire de filtre du pistolet**

Number	Qty.	V <sup>1</sup> /D <sup>2</sup> /R <sup>3</sup>	Artikelbezeichnung	Part Description	Désignation des articles
0657376	2	V	Sieb – 40 Mesh	sieve - 40 Mesh	passoire – 40 Mesh
0656916	2	V	Sieb – 60 Mesh (Standard)	sieve - 60 Mesh	passoire – 60 Mesh
0657377	2	V	Sieb – 80 Mesh	sieve - 80 Mesh	passoire – 80 Mesh

<sup>1</sup>V = Verschleißteile • Wear parts • Pièces d'usure usuelles

<sup>2</sup>D = Teile des Dichtungssatzes • Parts of seal kit • Pièces de kit de joints

<sup>3</sup>R = Teile des Reparatursatzes • Parts of repair kit • Pièces de kit de réparation

**Hauptsitz und Produktion / Headquarter & Production**

**WIWA Wilhelm Wagner GmbH & Co. KG**  
 Gewerbestraße 1-3 • 35633 Lahnau, Germany  
 Tel: +49 6441 609-0 • Fax: +49 6441 609-50  
 E-Mail: info@wiwa.de  
 Internet: www.wiwa.de

**WIWA Subsidiary USA**

107 N.Main St. • P.O.Box 398, Alger, OH 45812  
 Tel: +1-419-757-0141 • Fax: +1-419-549-5173 •  
 Toll Free: +1-855-757-0141  
 E-Mail: sales@wiwa.com  
 Internet: www.wiwausa.com

**PU - Pistole**  
**PU - gun**  
**PU - pistolet**

Bestell-Nr. • Order-No. • Référence: **0666844**  
 Serie • Serie • Série: **001**  
 Datum • Date • Date: **14.12.2023**



**4040 - automatic**

**Sicherungsmittel / Thread sealant / produit d'étanchéité**

Symbol / Symbol / Symbole	Beschreibung / Description / Description	Artikel / Bestell-Nr. Article / Order-No. L'article / Référence
[r]	schwach / light / léger	222 / 0000016
[b]	mittel / medium / léger	243 / 0000015
[schw]	mittel, Kunststoff-Stahl / medium, plastic-steel / medium, platique-acier (20ml)	480 / 0000107
[g]	hochfest / high-streng / hautesistance (50ml) hochfest für Cr/Ni-Teile / for Cr/Ni steel parts / pour parties fabriquée de Cr/Ni (50ml)	601 / 0000014 2701 / 0000303
[p]	Rohrdichtungspaste / pipe sealant / pâte d'étanchéité pour tuyaux(50ml)	225 / 0000017
[a]	Aktivator / activator / activateur (500ml) Aktivator für Kunststoffteile / activator for plastic parts / activateur pour pièces de plastique (10ml)	734 / 0000018 770 / 0000108
[t]	Gewindeband / threaded tape / ruban de filetage	/0000099
[k]	2K - Kleber / 2K - adhesive / 2K - adhésif	/0000414

**Betriebsmittel / Machinery materials / Equipement de production**

Symbol / Symbol / Symbole	Beschreibung / Description / Description	Artikel / Bestell-Nr. Article / Order-No. L'article / Référence
[F]	Fett, säurefrei / acid-free / sans acide	0000025
[T]	Trennmittel / release agent / agent séparateur bei Verarbeitung von Isozyanate / for application with isozyanate / pour l'application de l'isozyanate	0163333 0640651
[M]	Montagepaste (für R- und RS- Ausführung) / assembly paste (for version R or RS) / pâte d'assemblage ( de version R et RS)	0000233
[MS]	Montagespray (für R- und RS- Ausführung) / assembly spray (for version R or RS) / aérosol d'assemblage ( de version R et RS)	0000118
[MT]	Montagepaste (für hohe Temperaturen) assembly paste (for high temperatures) d'assemblage (pour hautes températures)	0000057

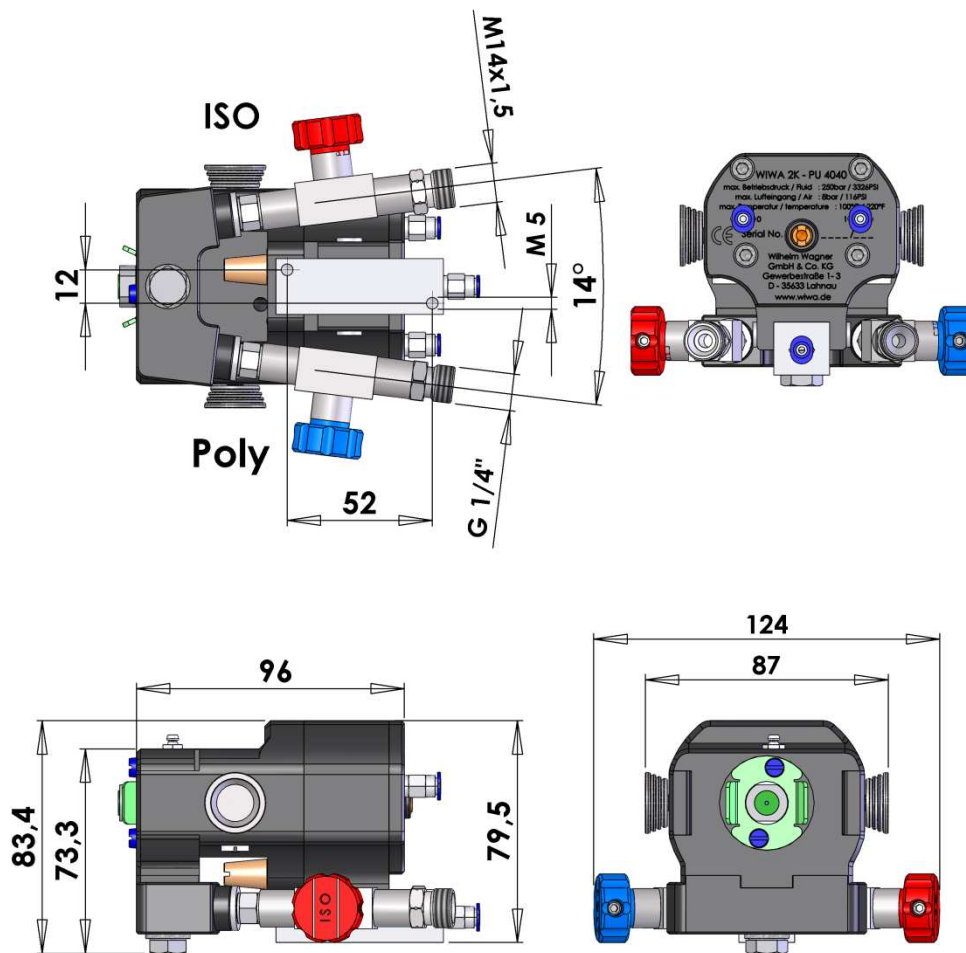

**Hauptsitz und Produktion / Headquarter & Production**

**WIWA Wilhelm Wagner GmbH & Co. KG**  
 Gewerbestraße 1-3 • 35633 Lahnhau, Germany  
 Tel: +49 6441 609-0 • Fax: +49 6441 609-50  
 E-Mail: info@wiwa.de  
 Internet: www.wiwa.de

**WIWA Subsidiary USA**

107 N.Main St. • P.O.Box 398, Alger, OH 45812  
 Tel: +1-419-757-0141 • Fax: +1-419-549-5173 •  
 Toll Free: +1-855-757-0141  
 E-Mail: sales@wiwa.com  
 Internet: www.wiwausa.com