

Materialpumpe
Material Pump
Section fluide

Bestell-Nr. • Order-No. • Référence: **0641538**

Serie • Serie • Série: **000**

Datum • Date • Date: **21.09.15**



ND 375 / 120 -N- mit Feder



Bild:0641538E.tif PL:W

Pos.-Nr. in Klammern () sind keine Bestandteile dieser Baugruppe / items marked with () are not part of assembly shown / Les pièces entre parenthèses ne font pas partie du sous-groupe

Diese Zeichnung darf nicht kopiert, vervielfältigt oder dritten Personen zugänglich gemacht werden. Widerrechtliche Benutzung hat strafrechtliche Folgen. / This drawing should not be, in whole or in part, copied, distributed or be used by or passed on as information to others for competition purposes or for whatever purposes without authorization. Unauthorized use is subject to prosecution.

Materialpumpe
Material Pump
Section fluide

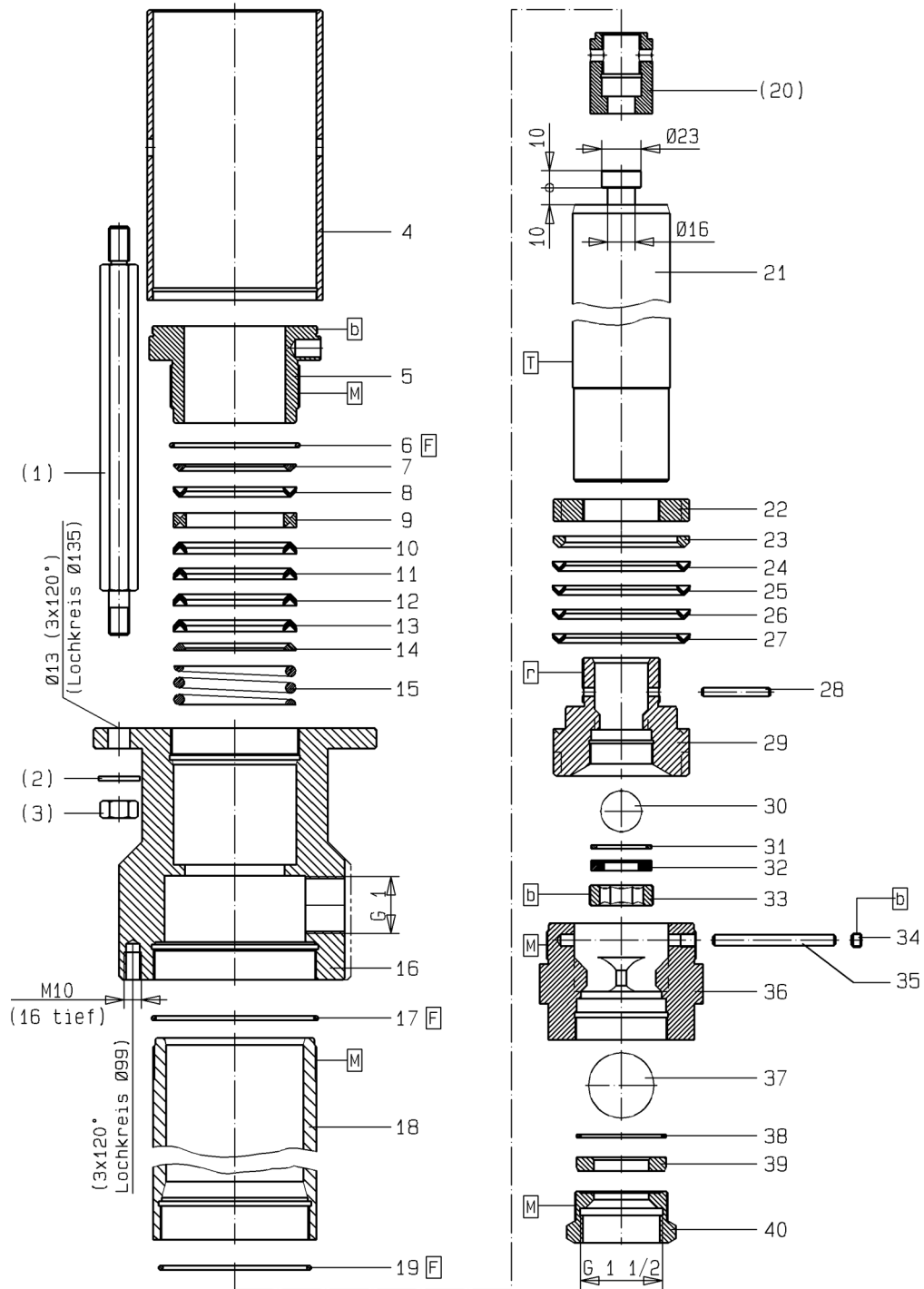
Bestell-Nr. • Order-No. • Référence: **0641538**

Serie • Serie • Série: **000**

Datum • Date • Date: **21.09.15**



ND 375 / 120 -N- mit Feder

Pos. Pos. Code	Bestell-Nr. Order-No. Référence	Stück Pieces Pièce	V ¹ / D ² / R ³	Artikelbezeichnung	Part Description	Désignation des articles
(1.)	0641529	3		Abstandbolzen	spacer bolt	boulon de distance
(2.)	0461091	3		U-Scheibe	washer	rondelle
(3.)	0460923	3		Mutter	nut	écrou
	0641546	1		Nachstelltasche bestehend aus Pos. 4+5	readjusting cup consisting of pos. 4+5	clapet de rajustage consistant en pos.4+5
4.	0641526	1		Rohr	tube	tube
5.	0641524	1		Schraubring	screw ring	anneau de blocage
6.	0640566	1	D, R	O-Ring	o-ring	joint torique
7.	0638943	1		Gegenring	counter ring	contre-anneau
	0638960	1	V, R	Manschettensatz bestehend aus Pos. 8-13	packing ring set consisting of pos. 8-13	jeu de joints consistant en pos. 8-13
8.	0638944	1	V, R	Manschette Leder	packing ring leather	joint en cuir
9.	0638945	1	R	Doppelsattelring	dual saddle ring	bague de retenue double
10.	0638946	1	V, R	Manschette Teflon	packing ring teflon	joint en teflon
11.	0638944	1	V, R	Manschette Leder	packing ring leather	joint en cuir
12.	0638946	1	V, R	Manschette Teflon	packing ring teflon	joint en teflon
13.	0638946	1	V, R	Manschette Teflon	packing ring teflon	joint en teflon
14.	0638943	1		Gegenring	counter ring	contre-anneau
15.	0641530	1		Druckfeder	spring	ressort
16.	0641527	1		Hochdruckkopf	high pressure head	tête à haute pression
17.	0638827	1	D, R	Dichtring	gasket	joint
18.	0639002	1	V	Druckzylinder	pressure cylinder	cylindre de pression
19.	0638952	1	D, R	Dichtring	gasket	joint
(20.)	0638849	1		Kupplungsstück	coupling piece	pièce d'accouplement
21.	0638825	1	V	Kolben	piston	piston
22.	0638937	1		Mutter	nut	écrou
23.	0638951	1		Gegenring	counter ring	bague de retenue
	0638961	1	V, R	Manschettensatz bestehend aus Pos. 24-27	packing ring set consisting of pos. 24-27	jeu de joints consistant en pos. 24-27
24.	0638947	1	V, R	Manschette Teflon	packing ring teflon	joint en teflon
25.	0638947	1	V, R	Manschette Teflon	packing ring teflon	joint en teflon
26.	0638948	1	V, R	Manschette Leder	packing ring leather	joint en cuir
27.	0638947	1	V, R	Manschette Teflon	packing ring teflon	joint en teflon
28.	0638938	1	V, R	Zylinderstift	cylinder pin	goupille cylindrique
29.	0638940	1		Ventilgehäuse	valve housing	boîte à soupape
30.	0638783	1	V, R	Kugel	ball	bille
31.	0642531	1	D, R	Dichtung	gasket	joint
32.	0638939	1	V	Ventilplatte	valve seat	siège de soupape
33.	0638941	1		Schraube	screw	vis
34.	0629485	1	R	Gewindestift	threaded pin	vis sans tête

Materialpumpe
Material Pump
Section fluide

Bestell-Nr. • Order-No. • Référence: **0641538**

Serie • Serie • Série: **000**

Datum • Date • Date: **21.09.15**



ND 375 / 120 -N- mit Feder

Pos. Pos. Code (Forts.)	Bestell-Nr. Order-No. Référence	Stück Pieces Pièce	V ¹ / D ² / R ³	Artikelbezeichnung	Part Description	Désignation des articles
35.	0638953	1	V, R	Zylinderstift	cylinder pin	goupille cylindrique
36.	0638954	1		Ventilgehäuse	valve housing	boîte à soupape
37.	0410551	1	V, R	Kugel	ball	bille
38.	0223387	1	D, R	Dichtung	gasket	joint
39.	0418501	1	V	Ventilplatte	valve seat	siège de soupape
40.	0638873	1		Schraube	screw	vis
	0638950		R	Dichtungssatz	seal kit	jeu de joints
	0638959			Reparatursatz	repair kit	jeu de réparation
				Werkzeuge für Montage- Demontage(ohne Abbildung)	tools for assembly -/ disassembly (not illustrated)	outillage pour montage- / démontage (sans illustration)
	0633576			Einmaulschlüssel für Pos. 16	open-jaw wrench for pos. 16	clé à fourche simple pour pos.16
	0465380			Einmaulschlüssel für Pos. 36	open-jaw wrench for pos. 36	clé à fourche simple pour pos.36
	0465372			Einmaulschlüssel für Pos. 22+29+40	open-jaw wrench for pos. 22+29+40	clé à fourche simple pour pos.22+29+40
				als Sonderausführung erhältlich:	optionally available:	disponible optionalement:
	0641650	1	V	Manschetten oben Manschetzensatz (SDM) bestehend aus:	packing ring upper packing ring set (SDM) consisting of:	joints supérieures jeu de joints (SDM) consistant en:
	0641259	1	V	Manschette SDM	packing ring SDM	joint en SDM
	0638945	1		Doppelsattelring	dual saddle ring	bague de retenue double
	0641259	1	V	Manschette SDM	packing ring SDM	jointe en SDM
	0641259	1	V	Manschette SDM	packing ring SDM	joint en SDM
	0641259	1	V	Manschette SDM	packing ring SDM	joint en SDM
	0641259	1	V	Manschette SDM	packing ring SDM	joint en SDM
	0644889	1	V	Manschetzensatz (Teflon) bestehend aus:	packing ring set (teflon) consisting of:	jeu de joints (teflon) consistant en:
	0638946	1	V	Manschette Teflon	packing ring teflon	joint en teflon
	0638945	1		Doppelsattelring	dual saddle ring	bague de retenue double
	0638946	1	V	Manschette Teflon	packing ring teflon	joint en teflon
	0638946	1	V	Manschette Teflon	packing ring teflon	joint en teflon
	0638946	1	V	Manschette Teflon	packing ring teflon	joint en teflon
	0638946	1	V	Manschette Teflon	packing ring teflon	joint en teflon
	0641651	1	V	Manschetten unten Manschetzensatz (SDM) bestehend aus:	packing ring lower packing ring set (SDM) consisting of:	joints inférieures jeu de joints (SDM) consistant en:
	0641652	1	V	Manschette SDM	packing ring SDM	joint en SDM
	0641652	1	V	Manschette SDM	packing ring SDM	joint en SDM
	0641652	1	V	Manschette SDM	packing ring SDM	joint en SDM
	0641652	1	V	Manschette SDM	packing ring SDM	joint en SDM
	0644890	1	V	Manschetzensatz (Teflon) bestehend aus:	packing ring set (teflon) consisting of:	jeu de joints (teflon) consistant en:

Materialpumpe
Material Pump
Section fluide

Bestell-Nr. • Order-No. • Référence: **0641538**

Serie • Serie • Série: **000**

Datum • Date • Date: **21.09.15**



ND 375 / 120 -N- mit Feder

Pos. Pos. Code (Forts.)	Bestell-Nr. Order-No. Référence	Stück Pieces Pièce	V ¹ / D ² / R ³	Artikelbezeichnung	Part Description	Désignation des articles
	0638947	1	V	Manschette Teflon	packing ring teflon	joint en teflon
	0638947	1		Doppelsattelring	dual saddle ring	bague de retenue double
	0638947	1	V	Manschette Teflon	packing ring teflon	joint en teflon
	0638947	1	V	Manschette Teflon	packing ring teflon	joint en teflon
	0644888			Reparaturatz (Manschetten Teflon)	repair kit (packing ring teflon)	kit de réparation (joint en teflon)

¹V= Verschleißteile • Wear parts • Pièces d'usure usuelles

²D= Teile des Dichtungssatzes • Parts of seal kit • Pièces de kit de joints

³R= Teile des Reparatursatzes • Parts of repair kit • Pièces de kit de reparation

³R_G = Teile des Reparatursatzes, groß • Parts of repair kit, big • Pièces de kit de reparation grand

³R_K = Teile des Reparatursatzes, klein • Parts of repair kit, small • Pièces de kit de reparation, petit

Sicherungsmittel / Thread sealant / produit d'étanchéité

Symbol / Symbol / Symbole	Beschreibung / Description / Description	Artikel / Bestell-Nr. Article / Order-No. L'article / Référence
r	schwach / light / léger (50 ml)	222 / 0000016
d	mittel / medium / médium (50 ml)	243 / 0000015
schw	mittel, Kunststoff-Stahl / medium, plastic-steel / medium, plastique-acier (20 ml)	480 / 0000107
g	hochfest / high-streng / hautesistance (50 ml) hochfest für Cr/Ni-Teile / for Cr/Ni steel parts / pour parties fabriqué de Cr/Ni (50 ml)	601 / 0000014 2701 / 0000303
p	Rohrdichtungspaste / pipe sealant / pâte d'étanchéité pour tuyaux (50 ml)	225 / 0000017
a	Aktivator / activator / activateur (500 ml) Aktivator für Kunststoffteile / activator for plastic parts / activateur pour pièces de plasti- que (10 ml)	734 / 0000018 770 / 0000108
t	Gewindeband / threaded tape / ruban de filetage	/ 0000099
k	2K - Kleber / 2K - adhesive / 2K - adhésif	/ 0000414

Betriebsmittel / Machinery materials / Équipement de production

Symbol / Symbol / Symbole	Beschreibung / Description / Description	Bestell-Nr. Order-No. Référence
F	Fett, säurefrei / acid-free / sans acide	0000025
T	Trennmittel / release agent / agent séparateur bei Verarbeitung von Isozyanat / for application with isocyanate / pour l'application de l'isocyanate	0163333 0640651
M	Montagepaste (für R- und RS-Ausführung) / as- sembly paste (for version R or RS) / pâte d'as- semblage (de version R et RS)	0000233
MS	Montagespray (für R- und RS-Ausführung) / as- sembly spray (for version R or RS) / aérosol d'as- semblage (de version R et RS)	0000118