

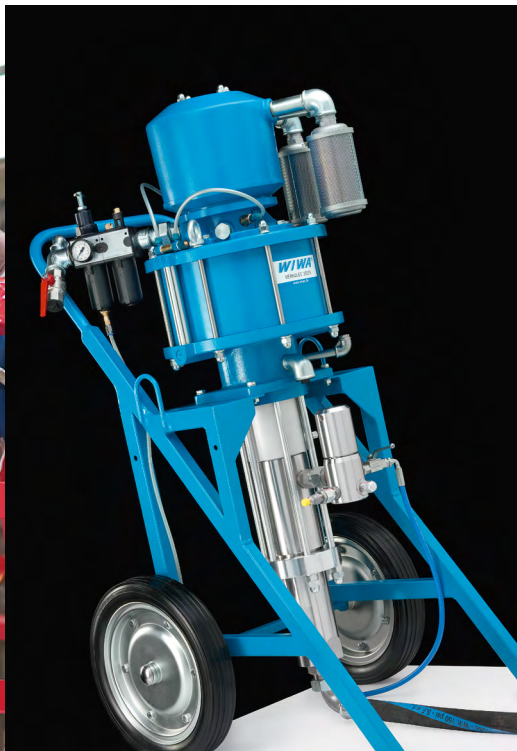

Your project deserves it.



PROFESSIONAL / HERKULES

WWW.WIWA.COM

PROFESSIONAL + HERKULES – AIRLESS HIGH PERFORMANCE UNITS



WIWA PROFESSIONAL



WIWA HERKULES

New standards for efficiency and performance under extreme conditions

WIWA is globally renowned through its premium-quality, robust pumps for all areas of application. The equipment in the PROFESSIONAL and HERKULES series is setting new standards for efficiency and performance. It particularly highlights its strengths in the toughest of everyday uses, e.g. for large surface coverage and thick coatings in the marine, offshore and pipe coating industries or for structural and corrosion protection. However, high performance also means the highest demands on all components. This is where WIWA's long standing global experience comes to bear; premium quality materials, a sophisticated design and precise manufacturing make the equipment in the PROFESSIONAL and HERKULES series durable and easy to service. All Airless paint spraying units in the PROFESSIONAL and HERKULES series are also available as, or can be converted into Hot Job spraying units or Air Combi units for finer finishes. These pumps are pneumatically driven and rated explosion proof. Let WIWA's 60+ years of experience work for you!

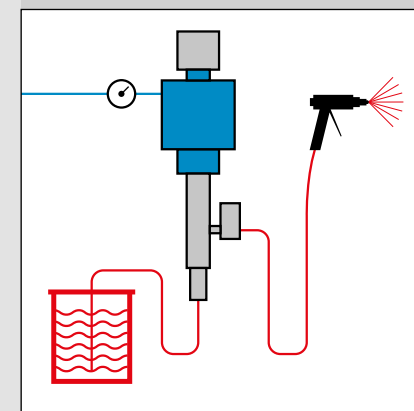

WIWA PROFESSIONAL and HERKULES, available as Airless spraying units

AIRLESS High pressure

Economical, environmentally friendly spraying method with excellent surface area coverage at high pressures.

The high pressure pump draws the spraying agent from any desired container and transfers it to the spray gun under high pressure via a high pressure hose.

Fine, airless atomisation is achieved through a specially designed spray nozzle. The spray jet is directed onto the material at high speed, thereby providing an optimal finish.

The benefits at a glance:

- Effective painting and coating of large surfaces
- Higher coating thickness in just one pass
- Saves materials and solvent
- Closed, uniform spray pattern
- Better use of energy due to minimal air consumption
- Environmental friendly as no spray mist when correctly configured

Existing Airless spraying units can be converted into the Air Combi system.

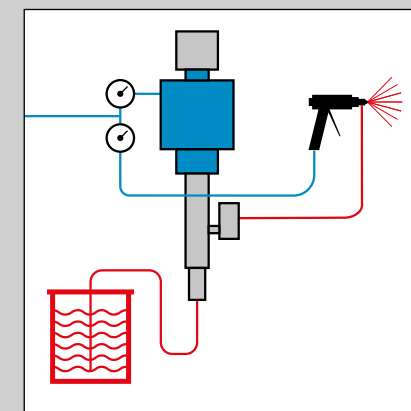

WIWA PROFESSIONAL, available as Air Combi finishing systems for painting lines and paint circulation systems

AIR COMBI Air-assisted painting

The Air Combi combines the advantages of Airless and conventional spraying techniques.

Using this painting method, the spraying agent is transferred to the spray gun under moderate pressure and pre-atomised. The fine spray distribution is achieved by applying regulated compressed air as the paint is discharged. A soft, controllable spray jet is produced with minimum paint mist.

Ideal for highly refined painting tasks on large surface areas as well as for angular components and shaped or small workpieces.

The benefits at a glance:

- The finest atomisation generates first class finishes
- High material savings
- Soft, controllable spray pattern
- Low operating costs due to minimal air consumption
- Low pump wear due to low material pressure
- Environmentally friendly due to minimal overspray

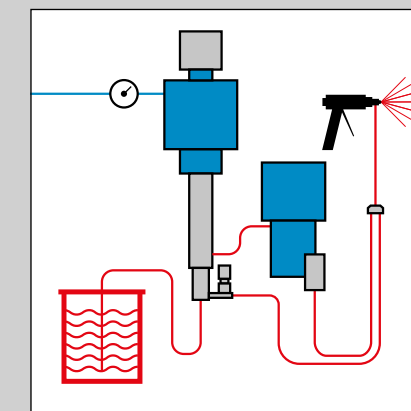

WIWA PROFESSIONAL and HERKULES, also available as Hot Job units with integrated fluid heater

HOT SPRAYING SYSTEMS

WIWA Hot Job systems for high film builds, short drying times, highest surface quality and extremely viscous coating materials.

During the hot spray process, the material is heated to the desired spraying temperature using the WIWA material flow heater.

This eliminates the need to use solvents to lower the viscosity.

An adjustable circulation system maintains a constant material temperature providing even coating and high finish quality.

The benefits at a glance:

- Highly viscous materials can be effortlessly processed
- High film builds
- Short drying periods
- Excellent surface coverage
- Glossier surfaces due to improved paint dispersion
- Environmentally and user friendly as no solvents are required

PROFESSIONAL – AIRLESS AND AIRLESS HOT SPRAYING IN THE HIGH PERFORMANCE CLASS



The art of
simplification
perfected:

WIWA PROFESSIONAL

WIWA Airless paint spraying units from the PROFESSIONAL series particularly demonstrate their strengths during the toughest use. This is guaranteed by their impressive, globally renowned durability. Spare parts enquiries are still received for units that are more than 20 years old, with most of these parts still being available. Could there be any better argument?

The simplest solution is the best. However, the demands on items that are ‚brilliantly simple‘ are enormous. Original WIWA Airless paint spraying units from the PROFESSIONAL series fulfill the high demands placed on simple solutions thanks to the years of experience of our development and production teams, carefully selected, high quality materials and our own production technology with the highest demands for perfection. Global recognition is also given to the return on investment during everyday use in the shipbuilding industry, the marine and offshore industry, the steelwork and bridge industry, pipe line construction and other areas of application of heavy-duty corrosion protection and multiple gun applications.

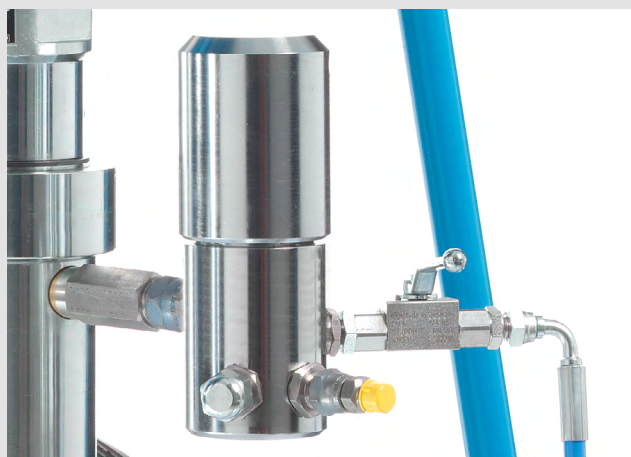

Standard high pressure filter on the pump outlet



Maintenance unit

THE ADVANTAGES OF THE PROFESSIONAL SERIES

- Dual action pump with long stroke and fixed packings.
- Maintenance free, low noise compressed air motor.
- Thorough cleaning through an innovative flushing system.
- A closed lubrication chamber separates the air motor and the material pump. The lubricant prevents paint from drying onto the piston rod and protects the packings.
- Large valve and material passages make processing highly viscous materials simple.
- Pre-tensioned, self adjusting packings reduce wear and tear and lower maintenance costs.
- Above-average service life due to hard chromed dual pistons, carbide faced valve plates and stainless steel valve balls.
- Dual filter system prevents downtime.
- The air motor is largely prevented from freezing by the standard, integrated air maintenance unit.
- Efficient use through the simultaneous feeding of several spray guns, depending on the nozzle size and the viscosity of the coating material.
- Environmentally friendly thanks to noise levels being kept to a minimum by the optimised control system and the large muffler.
- Perfect surfaces and larger area coverage.
- The low number of components makes maintenance simple.



PROFESSIONAL

PROFESSIONAL – CONFIGURATION OPTIONS

| PROFESSIONAL pumps for highly viscous coating materials | | | | | | | | |
|---|---------------------|---------------------|---------------------|---------------------|---------|---------|---------|---------|
| Model | 24071 | 28064 | 24053 | 28048 | | | | |
| Max. output | 24 l/min | 28 l/min | 24 l/min | 28 l/min | | | | |
| Pressure ratio | 71 : 1 | 64 : 1 | 53 : 1 | 48 : 1 | | | | |
| Pump capacity per double stroke | 138 cm ³ | 153 cm ³ | 138 cm ³ | 153 cm ³ | | | | |
| Max. air inlet pressure | 6,5 bar | 7 bar | 8 bar | 8 bar | | | | |
| Max. permissible operating pressure | 460 bar | 450 bar | 420 bar | 380 bar | | | | |
| Piston diameter of the air motor | 230 mm | 230 mm | 200 mm | 200 mm | | | | |
| Piston stroke of the air motor | 120 mm | 120 mm | 120 mm | 120 mm | | | | |
| Version | N | R | N | R | N | R | N | R |
| Pump with cart and maintenance unit (compact) | 0639061 | 0639180 | 0639063 | 0639184 | 0639279 | 0639282 | 0639285 | 0639288 |
| Pump on lift cart with maintenance unit (compact) | 0640057 | 0640058 | 0640018 | 0640017 | 0640055 | 6490056 | 0640059 | 0640060 |
| Pump with wall mount and maintenance unit (compact) | 0639062 | 0639181 | 0639064 | 0639185 | 0639280 | 0639283 | 0639286 | 0639289 |

| PROFESSIONAL pumps for medium and low-viscosity coating materials, automated spray and fluid circulation | | | | | | | | | | | | |
|--|---------------------|---------------------|---------------------|---------------------|---------------------|---------------------|---------|---------|---------|---------|---------|---------|
| Model | 38042 | 44032 | 38032 | 24026 | 44024 | 28023 | | | | | | |
| Max. output | 38 l/min | 44 l/min | 38 l/min | 24 l/min | 44 l/min | 28 l/min | | | | | | |
| Pressure ratio | 42 : 1 | 32 : 1 | 32 : 1 | 26 : 1 | 24 : 1 | 23 : 1 | | | | | | |
| Pump capacity per double stroke | 235 cm ³ | 306 cm ³ | 235 cm ³ | 138 cm ³ | 306 cm ³ | 153 cm ³ | | | | | | |
| Max. air inlet pressure | 8 bar | 8 bar | 8 bar | 8 bar | 8 bar | 8 bar | | | | | | |
| Max. permissible operating pressure | 335 bar | 255 bar | 255 bar | 210 bar | 190 bar | 185 bar | | | | | | |
| Piston diameter of the air motor | 230 mm | 230 mm | 200 mm | 140 mm | 200 mm | 140 mm | | | | | | |
| Piston stroke of the air motor | 120 mm | 120 mm | 120 mm | 120 mm | 120 mm | 120 mm | | | | | | |
| Version | N | R | N | R | N | R | N | R | N | R | N | R |
| Pump with cart and maintenance unit (compact) | 0639301 | 0639304 | 0639313 | 0639316 | 0639307 | 0639310 | 0643189 | 0643190 | 0639319 | 0639322 | 0643191 | 0643192 |
| Pump on lift cart with maintenance unit (compact) | 0640065 | 0640066 | 0640069 | 0640070 | 0640063 | 0640064 | - | - | 0640067 | 0640068 | - | - |
| Pump with wall mount and maintenance unit (compact) | 0639302 | 0639305 | 0639314 | 0639317 | 0639308 | 0639311 | 0643176 | 0643177 | 0639320 | 0639323 | 0643178 | 0643179 |

| Version | 38042 | 44032 | 38032 | 24026 | 44024 | 28023 |
|---|---------|---------|---------|---------|---------|---------|
| Mounting kits for hot spraying units on cart without circulation | 0640926 | 0640926 | 0640926 | 0630498 | 0640926 | 0630498 |
| Mounting kits for hot spraying units on wall mounts without circulation | 0640929 | 0640929 | 0640929 | 0630525 | 0640929 | 0630525 |
| Mounting kits for hot spraying units on cart with circulation | 0640078 | 0640078 | 0640078 | 0629398 | 0640078 | 0629398 |
| Mounting kits for hot spraying units on wall mounts with circulation | 0640928 | 0640928 | 0640928 | 0630531 | 0640928 | 0630531 |

Scope of delivery of the mounting kits: WIWA 3500 material flow heater with backflow regulator, temperature display and all necessary connection hoses and attachments

Spray accessory kit no. 05

for the 'ready-to-spray' version

Order no. 0621676 comprising:

- WIWA 500 D Airless spray gun (with swivel joint)
- NW 6 material hose (600 bar, 1/4", 15 m)
- REV-GUARD™ reversible guard with nozzle 627

Spray accessory kit no. 07 for the 'ready-to-spray' version for hot spraying units in the N and R versions:

Order no. 0621935 comprising:

- WIWA 500 F Airless spray gun (with swivel joint)
- 2 x NW 6 material hose (410 bar, 7.5m)
- 1 x NW 4 material hose (410 bar, 1.0 m)
- Manifold 3 x 1/4"
- Standard nozzle 40° - 0.53 mm

Spray accessory kit no. 12 for the 'ready-to-spray' version

Order no. 0640932 comprising:

- WIWA 500 F Airless spray gun
- NW 10 material hose (500 bar, 3/8", 15m)
- NW 6 material hose (600 bar, 1/4", 7.5 m)
- REV-GUARD™ reversible guard with nozzle 627

We recommend our special versions with an open system for glassflake materials.

N = Mild steel version R = Stainless steel version

DESIGN FEATURES OF THE PROFESSIONAL SERIES

Air motor:

- 1 The low number of components makes the motor easy to assemble and disassemble.
- 2 The toggles are clearly visible and thus easy to install.
- 3 Pulsation is barely noticeable thanks to the high stroke change-over speed.
- 4 Pressure ratio can be varied by changing the air motor piston diameter.

Lubrication chamber

- 5 A closed lubrication chamber separates the air motor and the material pump. The closed design prevents foreign objects such as blasting material from entering the pump system from the outside. The lubricant also prevents paint from drying onto the piston rod and protects the packings.

Material pump:

- 6 The pump components are quick to assemble and disassemble as they are simply connected by union nuts or by being screwed together.
- 7 Sealing rings located in front of the threads prevent the threads from sticking and make disassembly easier.
- 8 Precision bushings ensure simple and exact alignment of components and thus less wear and tear.
- 9 Large openings and voluminous fluid passages reduce pressure loss.
- 10 Better flushing due to large fluid passages and short packing tension springs.
- 11 The displacement and pressure ratio can be changed by exchanging the piston rod and packings.

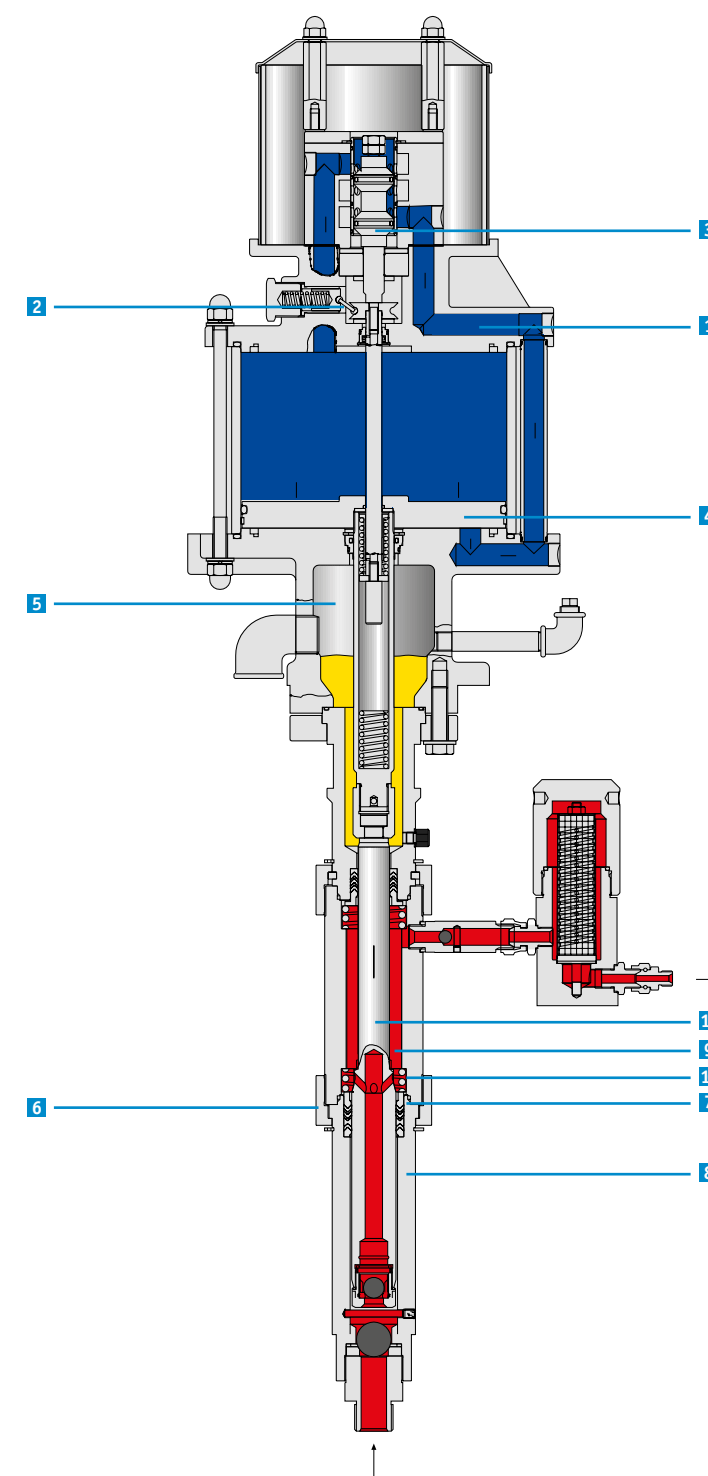

PROFESSIONAL

PROFESSIONAL – AREAS OF APPLICATION



| We recommend | PROFESSIONAL PUMPS for highly viscous coating materials | | | | PROFESSIONAL pumps for medium and low-viscosity coating materials, automated spray and fluid circulation | | | | | | |
|--------------------------------------|---|---------------------|---------------------|---------------------|--|---------------------|---------------------|---------------------|---------------------|---------------------|--|
| Model | 24071 | 28064 | 24053 | 28048 | 38042 | 44032 | 38032 | 24026 | 44024 | 28023 | |
| Max. output | 24 l/min | 28 l/min | 24 l/min | 28 l/min | 38 l/min | 44 l/min | 38 l/min | 24 l/min | 44 l/min | 28 l/min | |
| Pressure ratio | 71 : 1 | 64 : 1 | 53 : 1 | 48 : 1 | 42 : 1 | 32 : 1 | 32 : 1 | 26 : 1 | 24 : 1 | 23 : 1 | |
| Pump capacity per double stroke | 138 cm ³ | 153 cm ³ | 138 cm ³ | 153 cm ³ | 235 cm ³ | 306 cm ³ | 235 cm ³ | 138 cm ³ | 306 cm ³ | 153 cm ³ | |
| Areas of application | | | | | | | | | | | |
| Large surfaces | ● | ● | ● | ● | ● | ● | ● | ● | ● | ● | |
| Ship painting | ● | ● | ● | ● | ● | ● | ● | ○ | ○ | ○ | |
| Steel and hall construction | ● | ● | ● | ● | ● | ● | ● | ○ | ○ | ○ | |
| Railcar construction | ● | ● | ● | ● | ● | ● | ● | ● | ○ | ○ | |
| Paint and finishing shops | ● | ● | ● | ● | ● | ● | ● | ○ | ○ | ○ | |
| Offshore industry | ● | ● | ● | ● | ● | ● | ● | ○ | ○ | ○ | |
| Industrial coatings | ● | ● | ● | ● | ● | ● | ● | ○ | ○ | ○ | |
| Structural and corrosion protection | ● | ● | ● | ● | ● | ● | ● | ○ | ○ | ○ | |
| Insulation | ● | ● | ● | ● | ● | ● | ● | ○ | ○ | ○ | |
| Fire prevention | ○ | ○ | ○ | ○ | ● | ● | ● | — | — | — | |
| Transfer pumps | — | — | — | — | ○ | ○ | ○ | — | ● | — | |
| Spraying agent | | | | | | | | | | | |
| Abrasive materials* | ○ | ○ | ○ | ● | ● | ● | ● | ● | ● | ● | |
| Flame protection materials | — | ○ | ○ | ● | ● | ○ | ○ | — | — | — | |
| Glassflake | ● | ● | ● | ● | ○ | ○ | ○ | — | — | — | |
| Insulated and thick-film materials | ○ | ● | ○ | ● | ● | ○ | ○ | — | — | — | |
| Anti-fouling | ● | ● | ● | ● | ● | — | — | — | — | — | |
| Cold bitumen | ● | ● | ● | ○ | ○ | — | — | — | — | — | |
| Materials with short fibres | ● | ● | ● | ○ | ○ | ○ | — | — | — | — | |
| Low-solvent and solvent-free paints | ● | ● | ● | ● | ○ | ○ | ○ | ○ | — | — | |
| Sprayable paints and varnishes | ● | ● | ● | ● | ● | ● | ● | ● | ● | ● | |
| Two component and tar/epoxy paints** | ● | ● | ● | ● | ● | — | — | — | — | — | |

● Very suitable ○ Suitable — Unsuitable

* With low to medium viscosity, such as zinc primer, micaceous iron ore, solvent-based zinc silicate

** Highly viscous and coarsely pigmented

AREAS OF APPLICATION FOR THE PROFESSIONAL SERIES

- Large surfaces
- Ship building
- Steel and hall construction
- Railcar construction
- Paint and finishing shops
- Offshore industry
- Industrial coatings
- Structural and corrosion protection
- Insulation
- Fire prevention
- Coating and finishing systems

Units with higher pressure ratios

Particularly suited for use with highly viscous, low-solvent and solvent free materials with a high solids content. Optimally suited for larger nozzle bores, long hoses and high pressures. Significant pressure reserves compensate for low or fluctuating air supply pressure

Units with higher displacement and lower pressure ratio

For use with coarsely pigmented or abrasive materials with low to medium viscosity. These units are also particularly suited for use with large tips and multiple spray guns.

Professional units with a lower pressure ratio are also optimally suited for paint supply systems in the Airless or Air-Combi procedures and for circulation lines for supplying paint.



PROFESSIONAL

HERKULES – AIRLESS AND AIRLESS HOT SPRAYING EQUIPMENT HIGH PERFORMANCE CLASS



WIWA HERKULES:
maximum performance
and durability
under extreme
conditions

Power, perfection and precision! The globally successful WIWA Airless pump range is achieving new levels of performance with the new WIWA HERKULES series. With pressure ratios of up to 75:1 and outputs of up to 550 cm³ per cycle, WIWA HERKULES pumps are the world's most powerful airless spraying units. Even materials that were previously non-sprayable or only sprayable under certain circumstances can be processed. The high delivery volume and the associated slow piston speed maintain a low level of wear even with large nozzle

bores and materials with high solids contents. The extraordinarily high performance data makes the WIWA HERKULES series ideal for use in shipyards and the offshore sector, structural and fire protection, automatic spraying systems and other major projects that require top performance and no downtime.

THE ADVANTAGES OF THE HERKULES SERIES

- Efficient coating of large surfaces.
- Large area output and high film builds.
- Can be easily operated with hose lengths in excess of 100 m.
- Maximum performance even in the toughest conditions.
- Several spray guns can be used, even with extremely long hoses.
- Large power reserves even if the pressure is low on the compressed air supply network.
- Economical due to the robust unit technology and high durability.
- Quick maintenance due to simple installation.
- Large valve and material passages make processing highly viscous materials simple.
- Self adjusting packings reduce wear and tear and lower maintenance costs.
- Above average service life due to hard chromed dual pistons, tungsten carbide valve seats and stainless steel balls.
- Dual filter system prevents downtime.
- 1" maintenance unit installed as standard.
- Environmentally friendly thanks to noise levels being kept to a minimum by the optimised control system and the large built in muffler.
- Ideal for automated spraying systems and paint circulation systems.



Standard high pressure filter on the pump outlet



Standard 1" maintenance unit



Low noise thanks to the voluminous muffler

HERKULES

HERKULES – CONFIGURATION OPTIONS

| Technical data | for extremely abrasive materials | | for medium to highly viscous materials | | for coating systems and paint circulation systems | |
|--|----------------------------------|---------------------|--|---------------------|---|---------------------|
| | 35075 | 35061 | 48057 | 48046 | 60036 | 60028 |
| Model | 35075 | 35061 | 48057 | 48046 | 60036 | 60028 |
| Max. output | 35 l/min | 35 l/min | 48 l/min | 48 l/min | 60 l/min | 60 l/min |
| Pressure ratio | 75 : 1 | 61 : 1 | 57 : 1 | 46 : 1 | 36 : 1 | 28 : 1 |
| Pump capacity per double stroke | 275 cm ³ | 275 cm ³ | 360 cm ³ | 360 cm ³ | 550 cm ³ | 550 cm ³ |
| Max. air inlet pressure | 6 bar | 7 bar | 7 bar | 8 bar | 8 bar | 8 bar |
| Max. permissible operating pressure | 450 bar | 427 bar | 399 bar | 368 bar | 288 bar | 224 bar |
| Piston diameter of the air motor | 333 mm | 300 mm | 333 mm | 300 mm | 333 mm | 300 mm |
| Piston stroke of the air motor | 120 mm | 120 mm | 120 mm | 120 mm | 120 mm | 120 mm |
| Version | R | R | R | R | R | R |
| Pump w. cart and R1" maintenance unit (3-piece)* | 0641375 | 0641376 | 0641377 | 0641378 | 0642026 | 0642025 |
| Pump on lift cart and R1" maintenance unit (3-piece)* | 0641729 | 0641728 | 0641731 | 0641730 | 0642028 | 0642027 |
| Pump w. wall mount and R1" maintenance unit (3-piece)* | 0642037 | 0642036 | 0642039 | 0642038 | 0642031 | 0642030 |
| Accessories set for ready-to-spray version = stainless steel version (RS on request) | Nr. 05 | | Nr. 04 | | Nr. 04 | |
| Version | 35075 | 35061 | 48057 | 48046 | 60036 | 60028 |
| Mounting kits for hot spraying units on cart without circulation | 0642222 | 0642238 | 0642222 | 0642222 | On request | On request |
| Mounting kits for hot spraying units on cart with circulation | 0642215 | 0642237 | 0642237 | 0642215 | On request | On request |

Scope of delivery of the mounting kits:
WIWA 3500 material flow heater with backpressure regulator, temperature display and all necessary fittings and attachments.



Spray accessory no. 04
Order no. 0621668 comprising:

- WIWA 500 D Airless spray gun (with swivel joint)
- NW6 material hose (410 bar, 1/4", 15 m)
- Reversible guard with reversible nozzle 627

Spray accessory no. 05
Order no. 0621676 comprising:

- WIWA 500 D Airless spray gun (with swivel joint)
- NW6 material hose (600 bar, 1/4", 15 m)
- Reversible guard with reversible nozzle 627

Accessories

- Suction filter and suction sieve for different pigment sizes. (Accessories)
- Stirrer mounting kit for continuous agitation of zinc materials or other separating fillers (Accessories)
- Hot spraying unit mounting kit
Heating extremely viscous coating materials makes it possible to vastly improve results and reduce solvent use. The WIWA material flow heater is also suitable for use with high ratio pumps. (Accessories)
- WIWA HERKULES with wall bracket
- WIWA HERKULES on lift trolley

DESIGN FEATURES OF THE HERKULES SERIES

Air motor

- 1 The low number of components makes the motor easy to assemble and disassemble.
- 2 The toggles are clearly visible and thus easy to install.
- 3 Minimal pulsation due to short change over time.
- 4 Pressure Ratio can be varied by changing the air motor piston diameter.

Lubrication chamber

- 5 A closed lubrication chamber separates the air motor and the material pump. The closed design prevents foreign objects such as blasting material from entering the pump system from the outside.
- The lubricant also prevents paint from drying onto the piston rod and protects the packings.

Material pump

- 6 The pump components are quick to assemble and disassemble.
- 7 Precision guides ensure simple and exact alignment of components and thus less wear and tear.
- 8 Large fluid passages reduce pressure loss.
- 9 Better flushing due to large fluid passages and short packing retention springs.

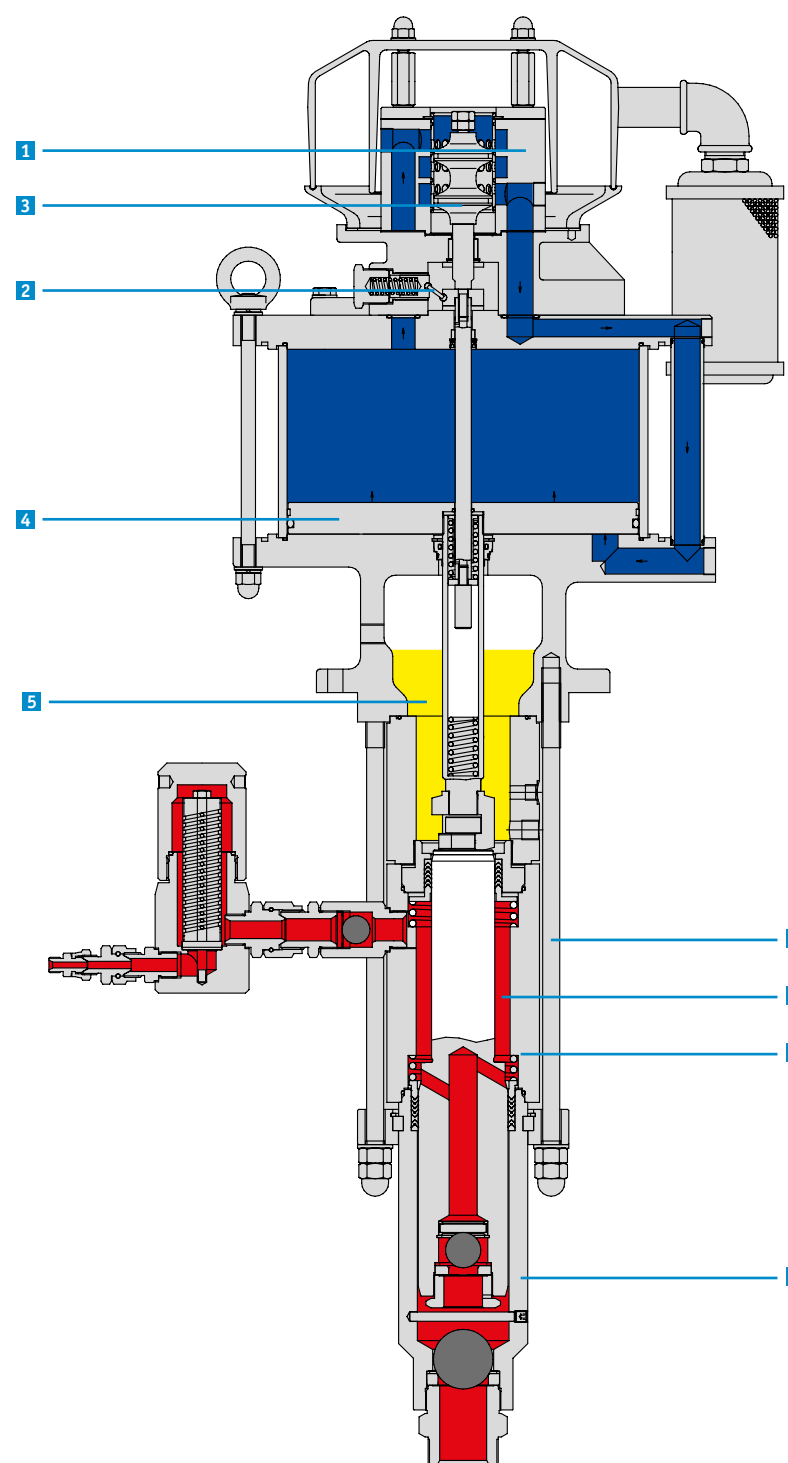

HERKULES

HERKULES – AREAS OF APPLICATION



| We recommend | | | | | | |
|---------------------------------|---------------------|---------------------|---------------------|---------------------|---------------------|---------------------|
| Model | 35075 | 35061 | 48057 | 48046 | 60036 | 60028 |
| Max. output | 35 l/min | 35 l/min | 48 l/min | 48 l/min | 60 l/min | 60 l/min |
| Pressure ratio | 75:1 | 61:1 | 57:1 | 46:1 | 36:1 | 28:1 |
| Pump capacity per double stroke | 275 cm ³ | 275 cm ³ | 360 cm ³ | 360 cm ³ | 550 cm ³ | 550 cm ³ |

Areas of application

| | | | | | | |
|-------------------------------------|---|---|---|---|---|---|
| Fire prevention | ○ | ○ | ● | ● | ● | — |
| Large surfaces | ● | ● | ● | ● | ● | ● |
| Ship building | ● | ● | ● | ● | ● | ● |
| Steel and hall construction | ● | ● | ● | ● | ● | ● |
| Railcar construction | ● | ● | ● | ● | ● | ● |
| Offshore industry | ● | ● | ● | ● | ○ | — |
| Industrial coatings | ● | ● | ● | ● | ● | — |
| Structural and corrosion protection | ● | ● | ● | ● | ● | — |
| Insulation | ● | ● | ● | ● | ● | ○ |
| Paint supply systems | — | — | — | ● | ● | ● |
| Automated coating systems | ● | ● | ● | ● | ● | ● |

Spraying agent

| | | | | | | |
|---|---|---|---|---|---|---|
| Glassflake | ○ | ● | ● | ● | ○ | — |
| Anti-fouling | ● | ● | ● | ● | ○ | — |
| Cold bitumen | ● | ● | ● | ○ | ○ | — |
| Low-solvent and solvent-free paints | ● | ● | ● | ○ | ○ | — |
| Materials with short fibres | — | ● | ● | ● | ● | — |
| Sprayable paints and varnishes | ● | ● | ● | ● | ● | ● |
| Two component and tar/epoxy paints* | ● | ● | ● | ● | ○ | — |
| Abrasive materials (zinc silicates and similar) | — | — | ○ | ● | ● | ● |
| Flame protection | — | ○ | ● | ● | ● | — |
| Insulated high-build materials | — | — | ○ | ● | ● | — |

● Very suitable ○ Suitable — Unsuitable

* highly viscous and coarsely pigmented

THE AREAS OF APPLICATION OF THE HERKULES SERIES

- Fire preventions
- Large surfaces
- Ship building
- Steel and hall construction
- Railcar construction
- Offshore industry
- Industrial coatings
- Structural and corrosion protection
- Insulation
- Paint supply systems
- Automated coating systems

WIWA HERKULES 35075 and 35061

The enormous pressure ratios make both of these models particularly suited for use with extremely viscous and solvent free materials with a high solids content. Significant pressure reserves compensate for low or fluctuating air supply pressure.

WIWA HERKULES 48057 und 48046

The higher output makes these units suitable for use with coarsely pigmented and abrasive materials or with fibre-filled coating materials with a medium to high viscosity.

WIWA HERKULES 60036 und 60028

The enormous output of 550 cm³ per double stroke makes these units ideal for use in multiple gun (automated or manual) spraying systems. They are also well suited for paint circulation systems and can be used for both Airless and Air-Assisted Airless applications



HERKULES

PRODUCT RANGE EXAMPLES

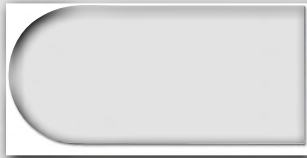

ATEX 94/9/EG

Headquarters and Production

WIWA Wilhelm Wagner GmbH & Co. KG
35633 Lahnau, Germany
Phone: +49 (0) 6441 609-0

www.wiwa.com

WIWA Subsidiary USA

WIWA LLC – USA, Canada, Latin America
107 N. Main St.
P.O. Box 398, Alger, OH 45812
Tel.: +1-419-757-0141
Fax: +1-419-549-5173
Toll-Free: +1-855-757-0141

www.wiwausa.com

WIWA Subsidiary China

WIWA (Taicang) Co., Ltd.
Taicang City
Jiangsu Province 215400, P.R.China
Phone: +86-512-53548857

www.wiwa-china.com

WIWA Middle East General Trading LLC

Jebel Ali Industrial 1
DUBAI, United Arab Emirates
Phone: +9714-884-8220

www.wiwa-middleeast.com



WIWA FLEXIMIX Electronic 2K
Paint Spraying and Coating Equipment



WIWA Fluid Transfer Pumps
for diverse applications



WIWA DUOMIX Plural Component
Airless Paint Spraying Equipment



WIWA Airless, Air-Combi
and Hot Spraying Systems

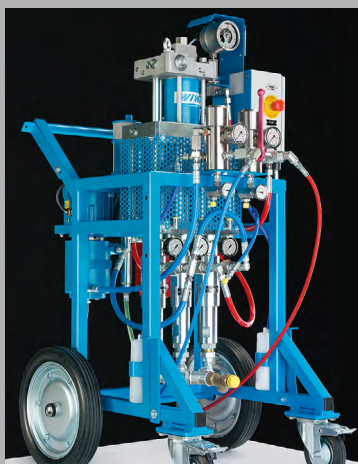

WIWA POWERPACK XXL 2K
Hydraulic Systems



WIWA PU 460
Polyurea Systems